

+ FLEXIBILITY
COMFORT



VCD SERIES

The real ventilation professional

- » Sophisticated and elegant solution for automated opening of bottom-hung, top-hung, side-hung vent and roof windows
- » Precise control using D+H original ACB bus technology
- » Low operating noise of a maximum of 46 dB(A)

+ DESIGN FUNCTION



Fig.: VCD Series
Colour finish: RAL 9006

Available as a **cost-effective TMS+ variant**
or **High End ACB variant**

The specialist for a fresh breeze

Tried-and-tested D+H technology for natural ventilation with technical and functional refinement. The chain drives of the VCD Series are suitable for almost all façade and roof windows. Thanks to optimised brackets, they can be installed quickly and used universally. The window drives are equipped with the Advanced Communication Bus (ACB), which is based on the open Modbus RTU. This allows the drives to be integrated directly into the building management system and controlled with precision down to the millimetre. Do you want your windows to open to just a tiny 50 mm gap in the summer? Or would you rather have 300 mm for a strong breeze? All details relating to programming can be found in the ACB planning manual, where you can freely view all ventilation commands for ACB components.

It is not only this bus technology that makes the VCD capable of top-notch ventilation, however - its elegant design is a

significant factor as well. Thanks to its slim construction using solid die-cast zinc, the VCD Series features minimal dimensions with high functionality and performance power. The high-performance chains made of hardened and galvanised steel offer 200 N of force of pressure and tensile force. If needed, the opening stroke can be configured stepless for the TMS+ variant using a magnet. The ACB drives, on the other hand, can be configured quickly and easily using the D+H software SCS.

Thanks to its low operating noise and high level of adaptability, the VCD Series shows its power without being obtrusive. And power consumption is no exception: A current consumption level of just 0.35 A with 24 V drives allows control devices or power supply units to be considerably reduced in size. See for yourself: The VCD makes it incredibly easy to hook your windows up to the chain.



Reliable drive technology

- » Symmetrical design in the corresponding, state of the art design (VCD 204 und VCD-0204-ACB)
- » Convenient, error-free installation thanks to a pre-fabricated pluggable cable connection with 2.5 m cable
- » Available in a 24 V DC or 230 V AC design
- » Solid housing made from powder-coated die-cast zinc
- » Especially long-lasting, maintenance-free chain with lifetime wax
- » Low operating noise of ≤ 46 dB(A)
- » Can be combined with locking drives (24 V)
- » Saves energy thanks to outstandingly low current consumption
- » Synchronous operation of up to 8 ACB drives
- » ACB drives can be remotely configured using the connected D+H controller
- » Tandem safety function ensures simultaneous shutdown if overload occurs (TMS+ variant)
- » Low programming effort: Only one TMS+ drive must be configured for tandem applications

ACB

Live communication with the drive

- » Less cable to be routed thanks to bi-directional bus communication between D+H controllers and D+H drives using just one BUS cable
- » Synchronous operation of multiple drives on one opening element easy to implement
- » Extension and retraction of the chain using precise control down to the millimetre
- » Quick and easy read-out of all status messages such as the opening stroke in mm or %, end position OPEN or CLOSED, optional messages for connecting closing edge protection, etc.
- » Direct integration into the building management system over an open Modbus RTU protocol
- » Virtual grouping allows up to 32 drives to be controlled on just one cable, either as a group or separately, meaning reduced cabling efforts and a more streamlined control panel system

For the ACB
planning manual



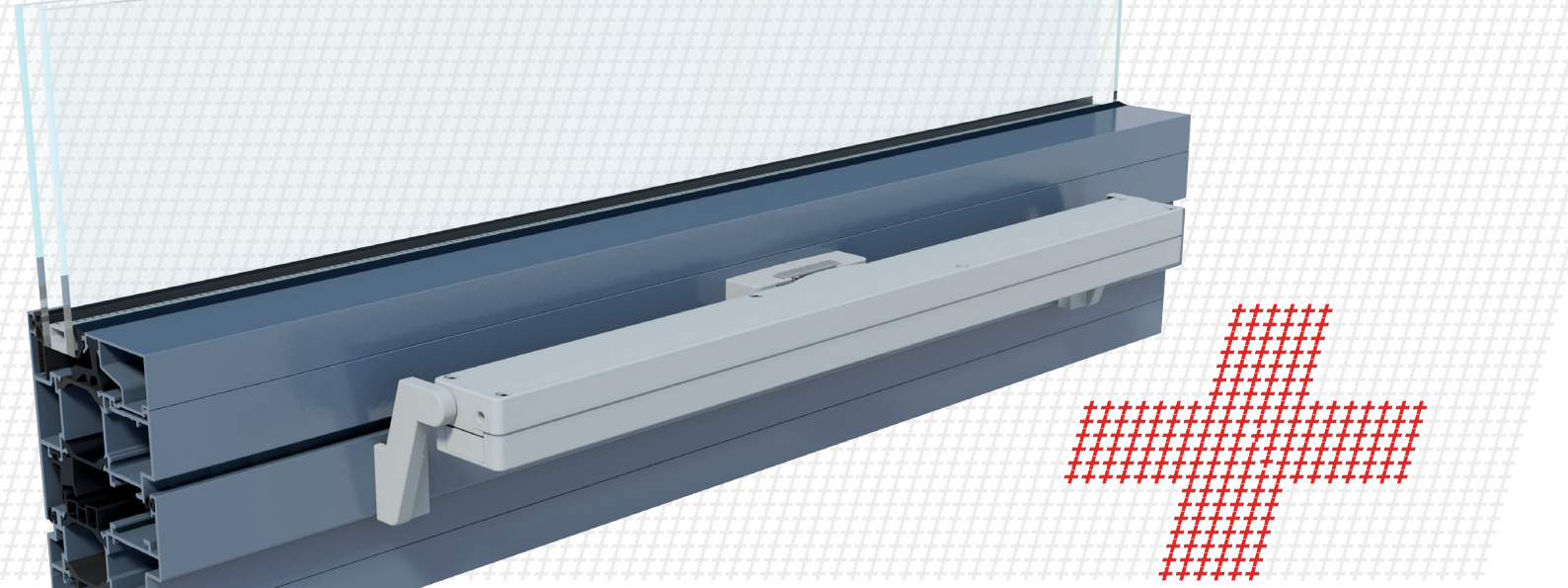

Fig.: VCD Series on the Hueck profile

+ EASY INSTALLATION

Mounting to measure and colour

The VCD Series is eye-catching for more than just one reason. In addition to looking great, this ventilation drive is a marvel to operate thanks to its bracket sets with the maximum in application options. Whether mounted on sash or frame - the chain drive leaves nothing to be desired in terms of flexibility of application. With colour-coordinated bracket covers and many other features, this refined, elegant drive series for the automated opening of bottom-hung, top-hung, side-hung vent and roof windows makes a smart, attractive system for ventilating your rooms naturally.



System vendors

Raico®
Reynaers®
Roto®
Schüco®
Velux®

If a suitable manufacturer is not listed for you, please contact our service regarding a solution.



VCD 203

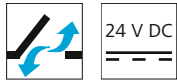

Performance features

- » For façade windows, roof windows and ventilation flaps in conservatories
- » With motor electronics controlled via microprocessor
- » "TMS+" tandem safety function for operating 2 drives on one sash
- » Option of chain stroke programming via magnet
- » Reprogrammed opening stroke is transmitted to the tandem drive
- » Simple connection via plug connector
- » Programmable drive functions and different drive parameters
- » Running speed in CLOSED direction decreases to 5 mm/s (passive closing edge protection)
- » Time-controlled reversing when an obstacle is detected in the CLOSED direction (active closing edge protection)

Potential drive options

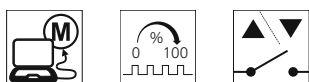

You can find the explanations for the icons in the legend.

Approvals / Certificates

Find out about permission details from your D+H Partner.



5014068.18003

Article also available with the following permissions under other article numbers. Technical data may deviate.



Technical data

For further information please contact your D+H partner.

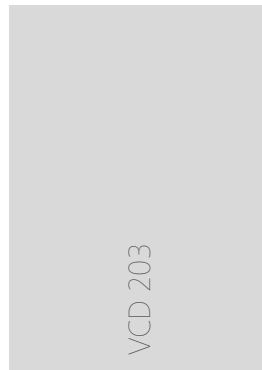

Supply	24 V DC / $\pm 20\%$
Rated input current	0.35 A
Force of pressure	200 N
Tensile force	200 N
Service life	20000 double strokes *
Stroke	250 mm
Type of protection	IP 30
Emission sound pressure level	LpA ≤ 46 dB(A)
Temperature range	0 °C ... +60 °C
Housing	Die-cast zinc
Colour	Silver (~ RAL 9006)
W x H x D	300 x 30 x 47 mm



* For vertical use, please consult with D+H Sales!

Dimensions

All specifications in mm

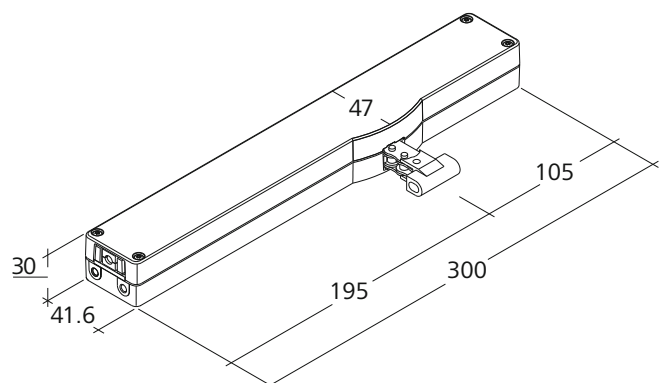
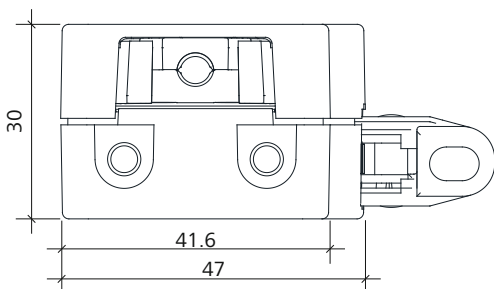

VCD-0203-1-ACB

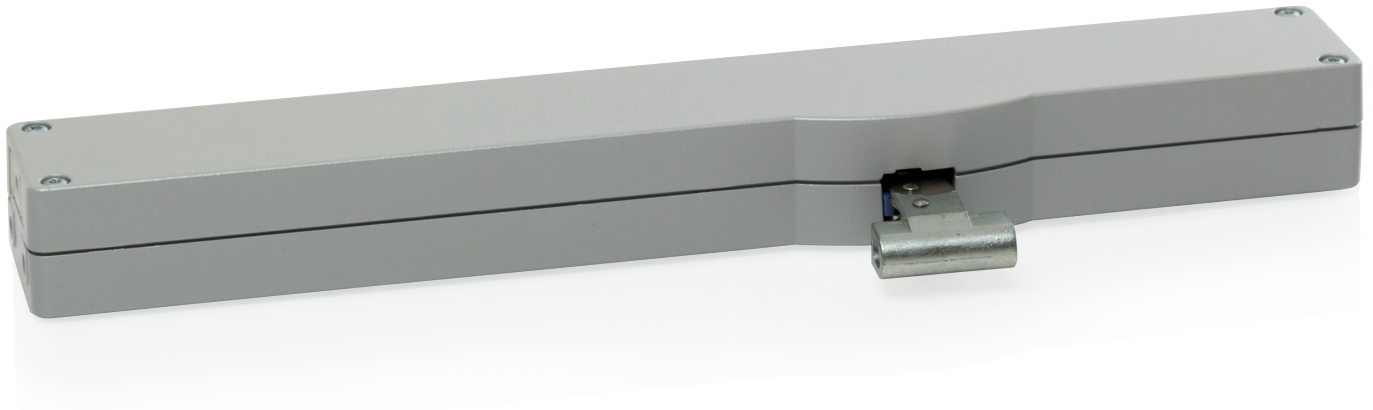
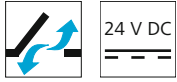

Performance features

- » For façade windows, roof windows and ventilation flaps in conservatories
- » With BSY+ motor and synchronised electronics controlled via microprocessor
- » Option of up to 8 drives in one synchronous group
- » Simple connection via plug connector
- » Programmable drive functions and different drive parameters
- » Running speed in CLOSED direction decreases to 5 mm/s (passive closing edge protection)
- » Time-controlled reversing when an obstacle is detected in the CLOSED direction (active closing edge protection)
- » Integrated ACB (Advanced Communication Bus) bus interface with Modbus RTU protocol
- » The drive is integrated directly via open bus communication through the ACB (Advanced Communication Bus), e.g. in a building management system

Potential drive options

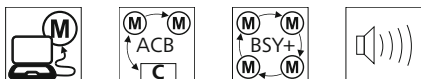

You can find the explanations for the icons in the legend.

Technical data

For further information please contact your D+H partner.

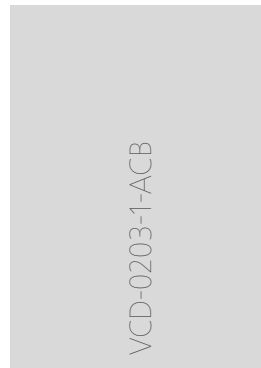

Supply	24 V DC / $\pm 20\%$
Rated input current	0.35 A
Force of pressure	200 N
Tensile force	200 N
Service life	20000 double strokes *
Stroke	250 mm
Type of protection	IP 30
Emission sound pressure level	LpA ≤ 46 dB(A)
Temperature range	0 °C ... +60 °C
Housing	Die-cast zinc
Colour	Silver (~ RAL 9006)
W x H x D	300 x 30 x 47 mm



* For vertical use, please consult with D+H Sales!

Dimensions

All specifications in mm

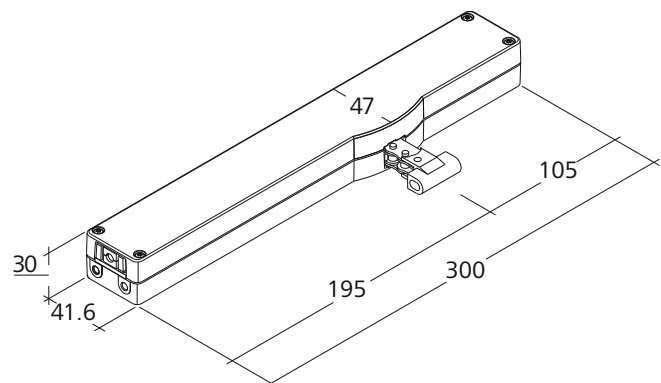
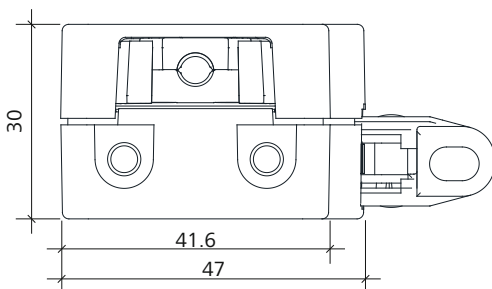

Pressure load diagram

VCD 203

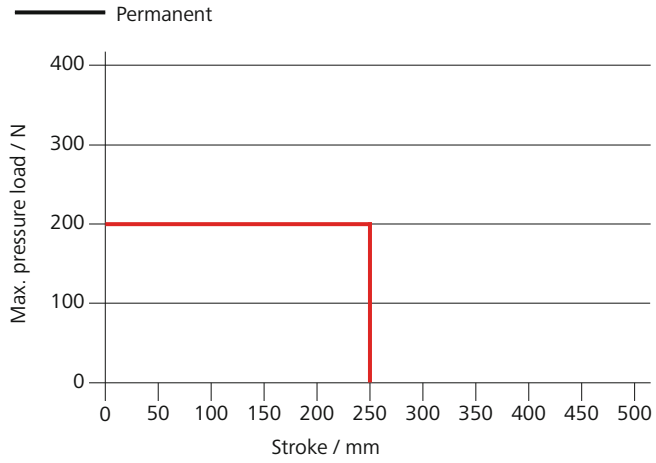

VCD-0203-1-ACB

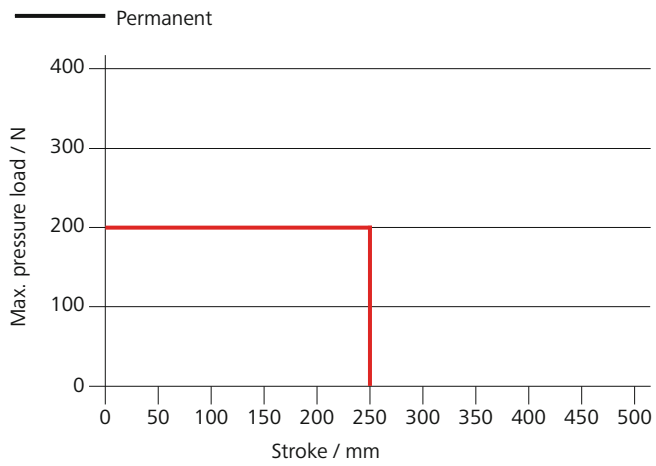

Installation example

Illustration provided as an example



- » Mounted installation
- » Sash mounting
- » Frame mounting
- » Application force
- » Application tension
- » Trapezoidal application (ACB drives)

Possible applications

VCD-0203-0250-1-ACB right / window locking drive FRA 11

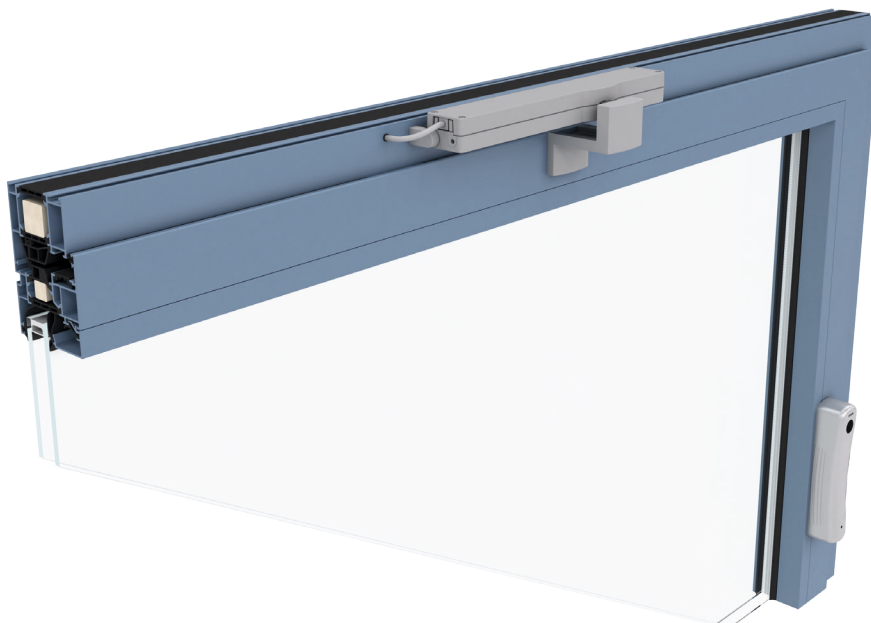

Brackets are not included and have to be ordered separately.

VCD 204 / VCD 204-TMS+ Set

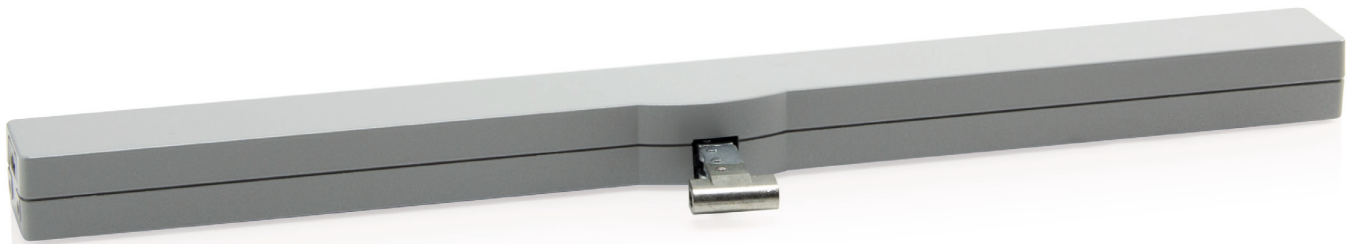
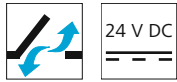

Performance features

- » For façade windows, roof windows and ventilation flaps in conservatories
- » With motor electronics controlled via microprocessor
- » Special chain stabilisation and centred chain outlet
- » "TMS+" tandem safety function for operating 2 drives on one sash
- » Option of chain stroke programming via magnet
- » Reprogrammed opening stroke is transmitted to the tandem drive
- » Direct cable guidance between the drives for visually appealing solution (VCD 204-TMS+ Set)
- » Simple connection via plug connector
- » Programmable drive functions and different drive parameters
- » Running speed in CLOSED direction decreases to 5 mm/s (passive closing edge protection)
- » Time-controlled reversing when an obstacle is detected in the CLOSED direction (active closing edge protection)

Potential drive options

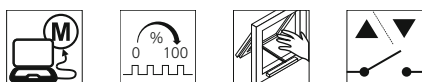

You can find the explanations for the icons in the legend.

Approvals / Certificates

Find out about permission details from your D+H Partner.



5014068.18003

Article also available with the following permissions under other article numbers. Technical data may deviate.



Technical data

For further information please contact your D+H partner.

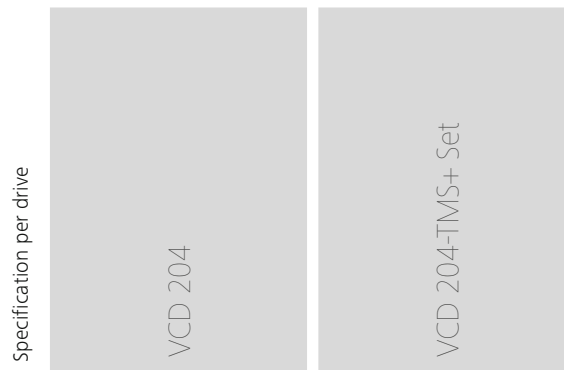

Supply	24 V DC / $\pm 20\%$
Rated input current	0.35 A
Force of pressure	200 N
Tensile force	200 N
Service life	20000 double strokes *
Stroke	250 - 350 mm
Type of protection	IP 30
Emission sound pressure level	LpA ≤ 46 dB(A)
Temperature range	0 °C ... +60 °C
Housing	Die-cast zinc
Colour	Silver (~ RAL 9006)
W x H x D	480 x 30 x 47 mm



* For vertical use, please consult with D+H Sales!

Dimensions

All specifications in mm

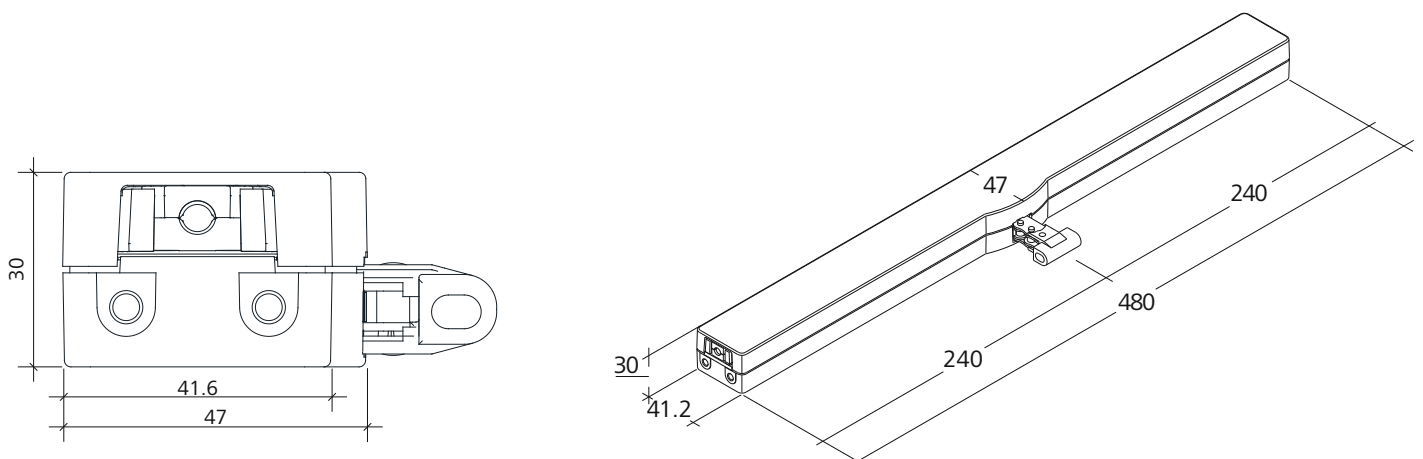

VCD-0204-1-ACB

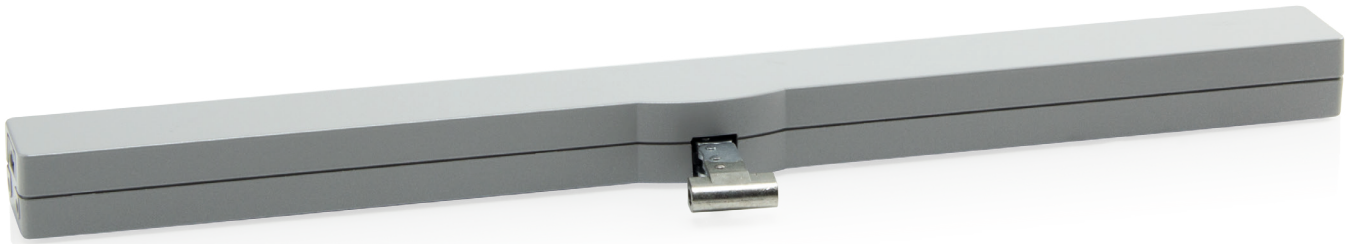
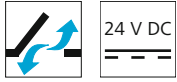

Performance features

- » For façade windows, roof windows and ventilation flaps in conservatories
- » With BSY+ motor and synchronised electronics controlled via microprocessor
- » Special chain stabilisation and centred chain outlet
- » Option of up to 8 drives in one synchronous group
- » Simple connection via plug connector
- » Programmable drive functions and different drive parameters
- » Running speed in CLOSED direction decreases to 5 mm/s (passive closing edge protection)
- » Time-controlled reversing when an obstacle is detected in the CLOSED direction (active closing edge protection)
- » Integrated ACB (Advanced Communication Bus) bus interface with Modbus RTU protocol
- » The drive is integrated directly via open bus communication through the ACB (Advanced Communication Bus), e.g. in a building management system

Potential drive options

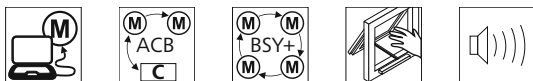

You can find the explanations for the icons in the legend.

Technical data

For further information please contact your D+H partner.

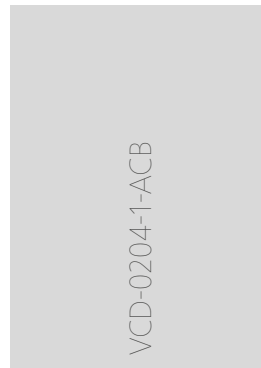

Supply	24 V DC / $\pm 20\%$
Rated input current	0.35 A
Force of pressure	200 N
Tensile force	200 N
Service life	20000 double strokes *
Stroke	250 - 350 mm
Type of protection	IP 30
Emission sound pressure level	LpA ≤ 46 dB(A)
Temperature range	0 °C ... +60 °C
Housing	Die-cast zinc
Colour	Silver (~ RAL 9006)
W x H x D	480 x 30 x 47 mm



* For vertical use, please consult with D+H Sales!

Dimensions

All specifications in mm

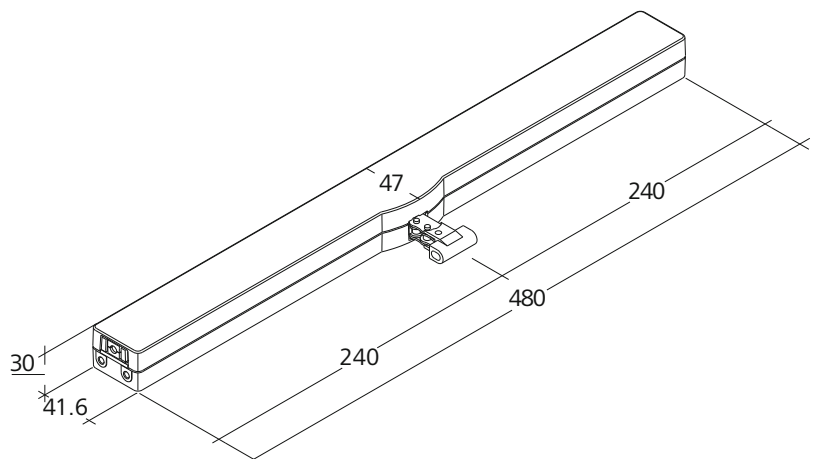
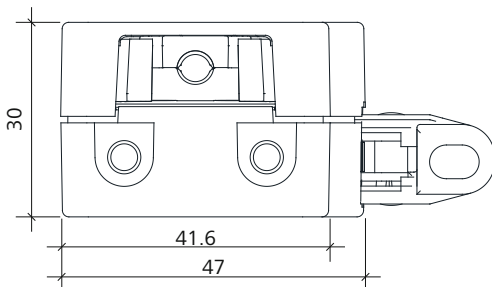

Pressure load diagram

Specification per drive

VCD 204

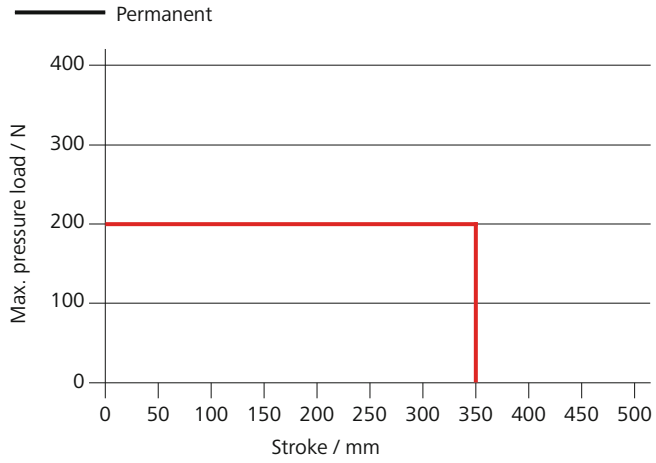

VCD 204-TMS+ Set

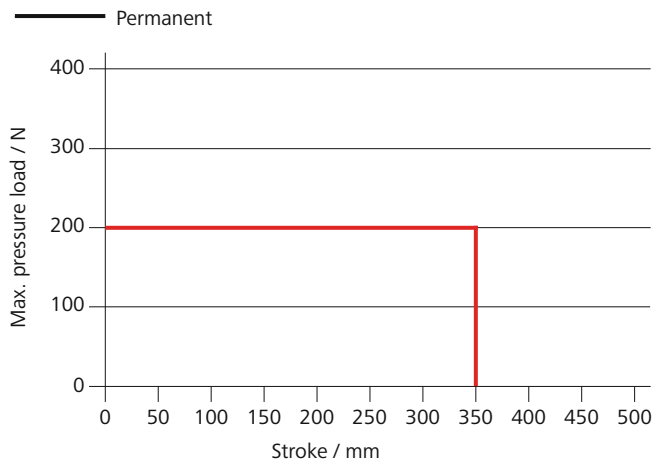

VCD-0204-1-ACB

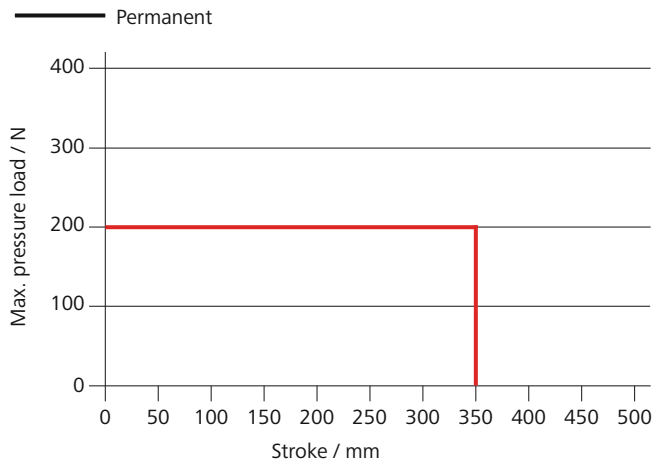

Possible applications

Illustration provided as an example

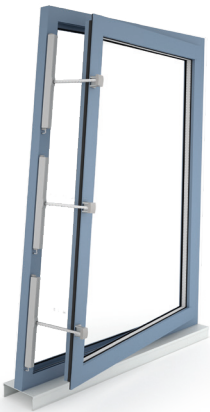
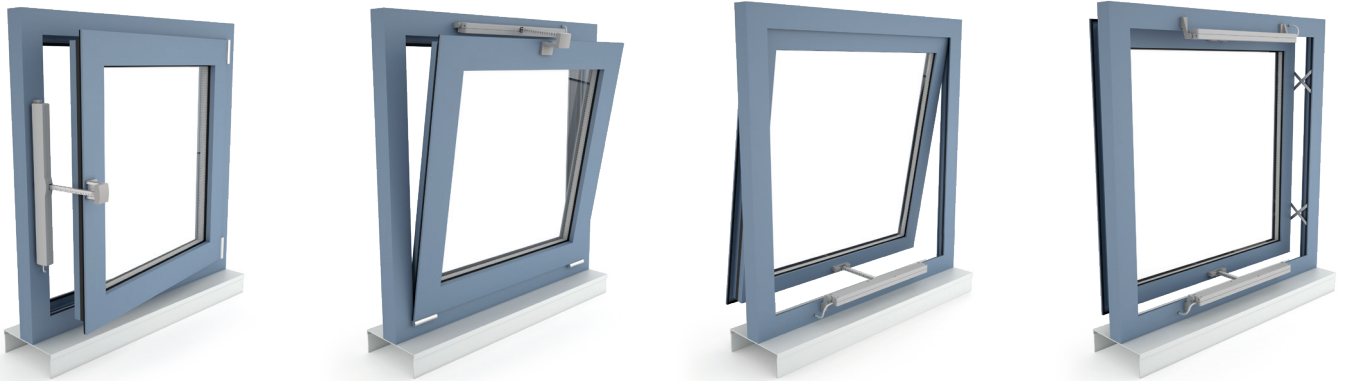

- » Mounted installation
- » Sash mounting
- » Frame mounting
- » Application force
- » Application tension
- » Trapezoidal application (ACB drives)

Installation example

VCD-0204-0350-1-ACB centic / window locking drive FRA 11

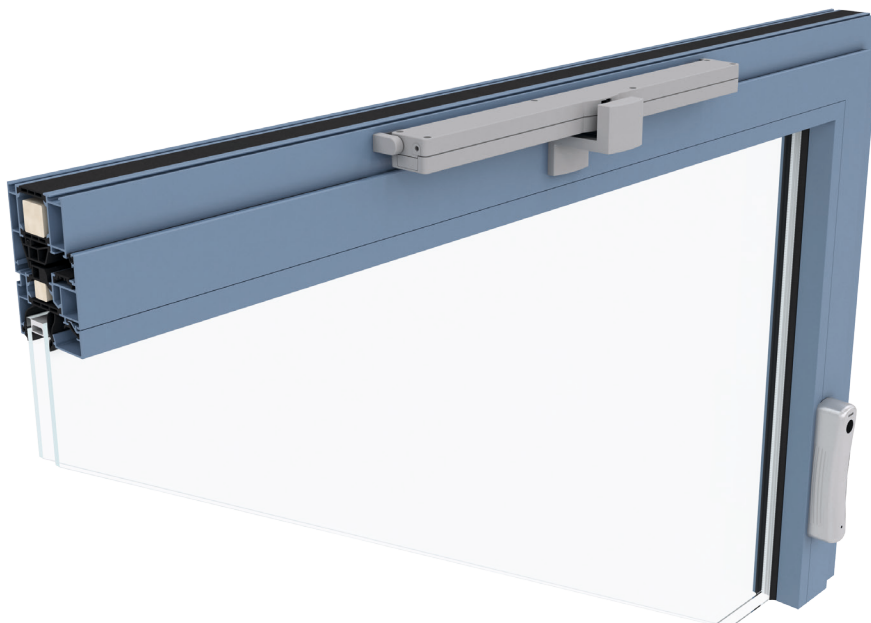

Brackets are not included and have to be ordered separately.

VCD 204-K / VCD 204-K-TMS+ Set

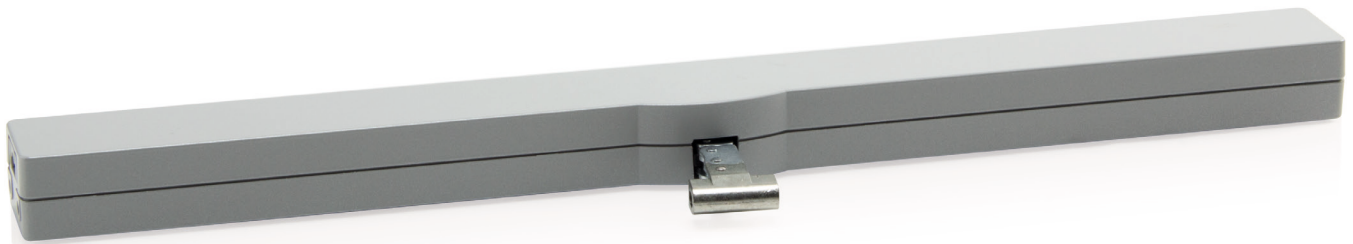
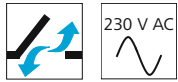

Performance features

- » For façade windows, roof windows and ventilation flaps in conservatories
- » With motor electronics controlled via microprocessor
- » Direct control via 230 V AC
- » Special chain stabilisation and centred chain outlet
- » "TMS+" tandem safety function for operating 2 drives on one sash (VCD 204-K-TMS+ Set)
- » Option of chain stroke programming via magnet
- » Reprogrammed opening stroke is transmitted to the tandem drive (VCD 204-K-TMS+ Set)
- » Simple connection via plug connector
- » Programmable drive functions and different drive parameters
- » Running speed in CLOSED direction decreases to 5 mm/s (passive closing edge protection)
- » Time-controlled reversing when an obstacle is detected in the CLOSED direction (active closing edge protection)

Potential drive options

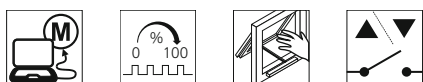

You can find the explanations for the icons in the legend.

Approvals / Certificates

Find out about permission details from your D+H Partner.



5014068.18003

Technical data

For further information please contact your D+H partner.

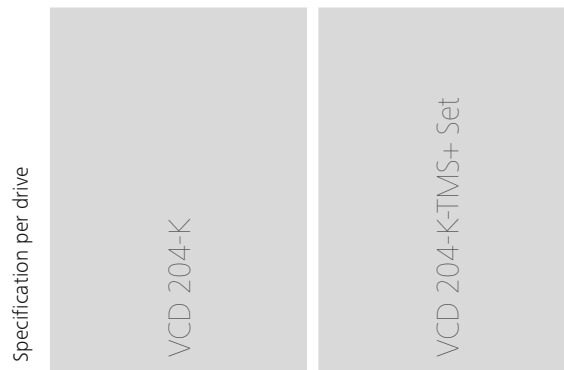

Supply	230 V AC / +10 % ... -15 %
Input frequency	50 ... 60 Hz
Performance	10 W / 15 VA
Force of pressure	200 N
Tensile force	200 N
Service life	20000 double strokes *
Stroke	250 - 350 mm
Type of protection	IP 30
Emission sound pressure level	LpA ≤ 46 dB(A)
Temperature range	0 °C ... +60 °C
Housing	Die-cast zinc
Colour	Silver (~ RAL 9006)
W x H x D	480 x 30 x 47 mm



* For vertical use, please consult with D+H Sales!

Dimensions

All specifications in mm

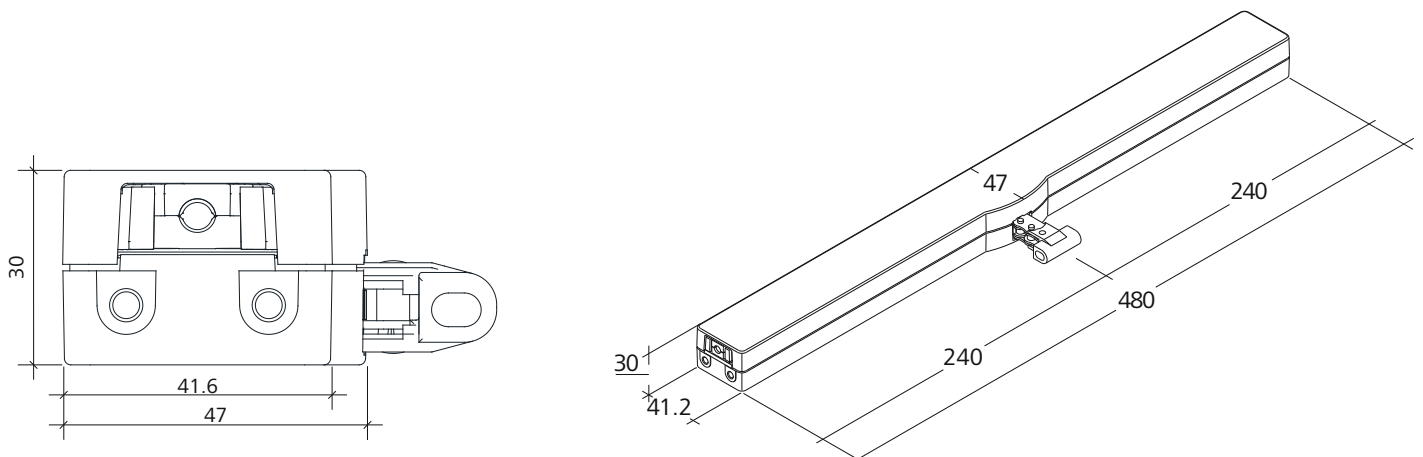

VCD-0204-5-ACB

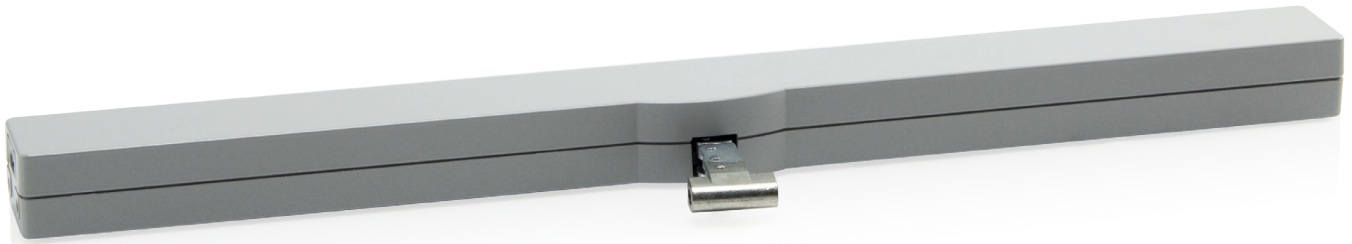
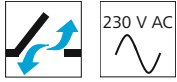

Performance features

- » For façade windows, roof windows and ventilation flaps in conservatories
- » With BSY+ motor and synchronised electronics controlled via microprocessor
- » Direct control via 230 V AC
- » Special chain stabilisation and centred chain outlet
- » 2 drives in one synchronous group possible
- » Simple connection via plug connector
- » Programmable drive functions and different drive parameters
- » Running speed in CLOSED direction decreases to 5 mm/s (passive closing edge protection)
- » Time-controlled reversing when an obstacle is detected in the CLOSED direction (active closing edge protection)
- » Integrated ACB (Advanced Communication Bus) bus interface with Modbus RTU protocol
- » The drive is integrated directly via open bus communication through the ACB (Advanced Communication Bus), e.g. in a building management system

Potential drive options

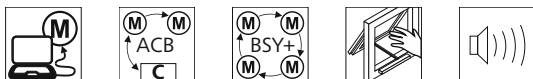

You can find the explanations for the icons in the legend.

Technical data

For further information please contact your D+H partner.

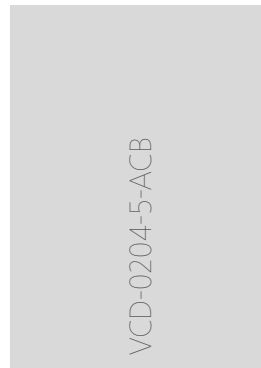

Supply	230 V AC / +10 % ... -15 %
Input frequency	50 ... 60 Hz
Performance	22 W / 30 VA
Force of pressure	200 N
Tensile force	200 N
Service life	20000 double strokes *
Stroke	250 - 350 mm
Type of protection	IP 30
Emission sound pressure level	LpA ≤ 46 dB(A)
Temperature range	0 °C ... +60 °C
Housing	Die-cast zinc
Colour	Silver (~ RAL 9006)
W x H x D	480 x 30 x 47 mm



* For vertical use, please consult with D+H Sales!

Dimensions

All specifications in mm

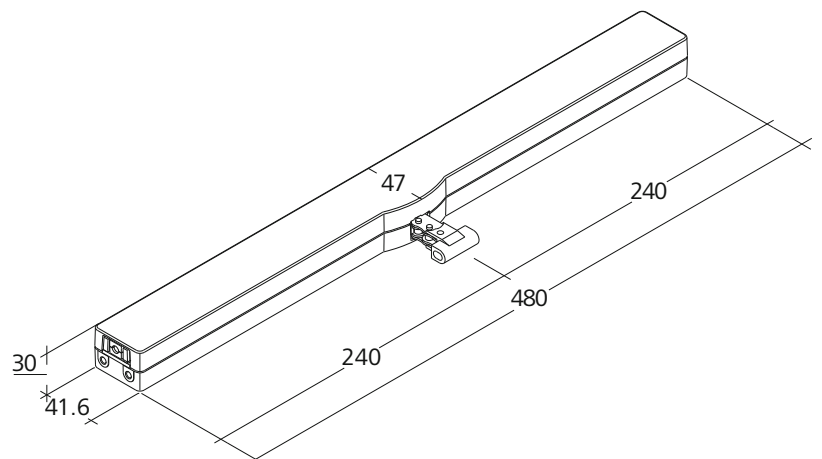
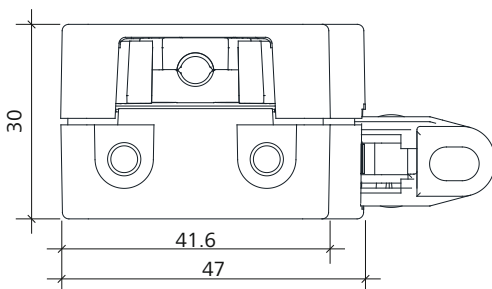

Pressure load diagram

Specification per drive

VCD 204-K

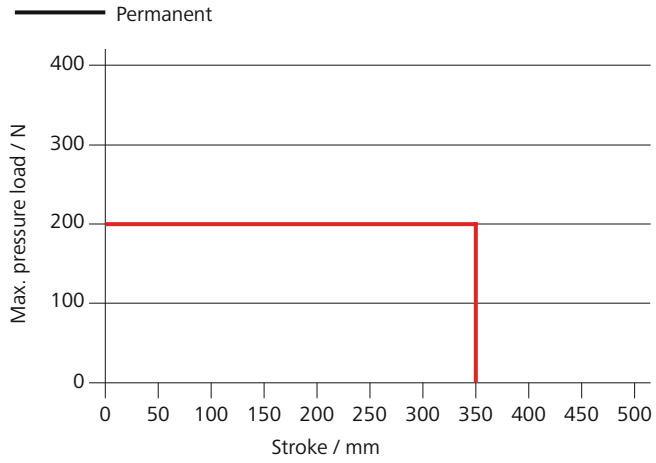

VCD 204-K-TMS+ Set

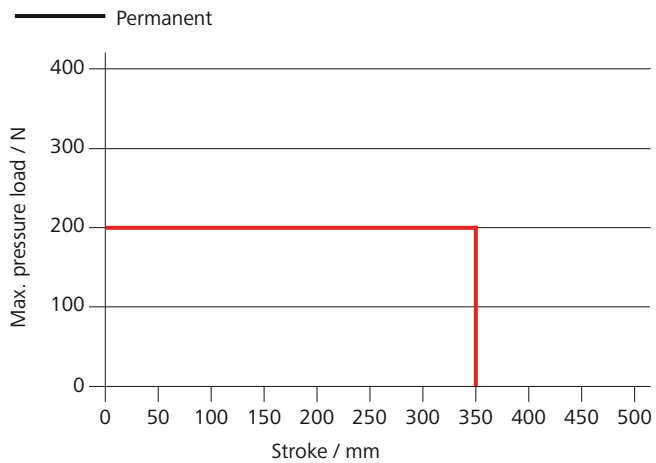

VCD-0204-5-ACB

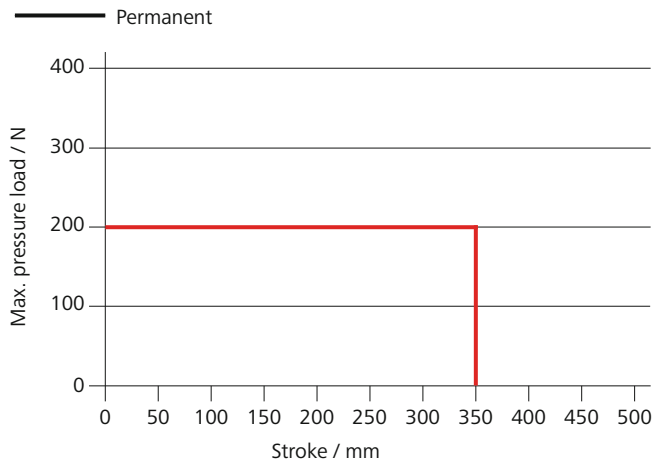

Possible applications

Illustration provided as an example

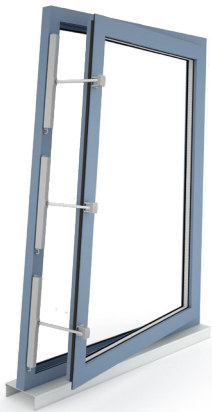
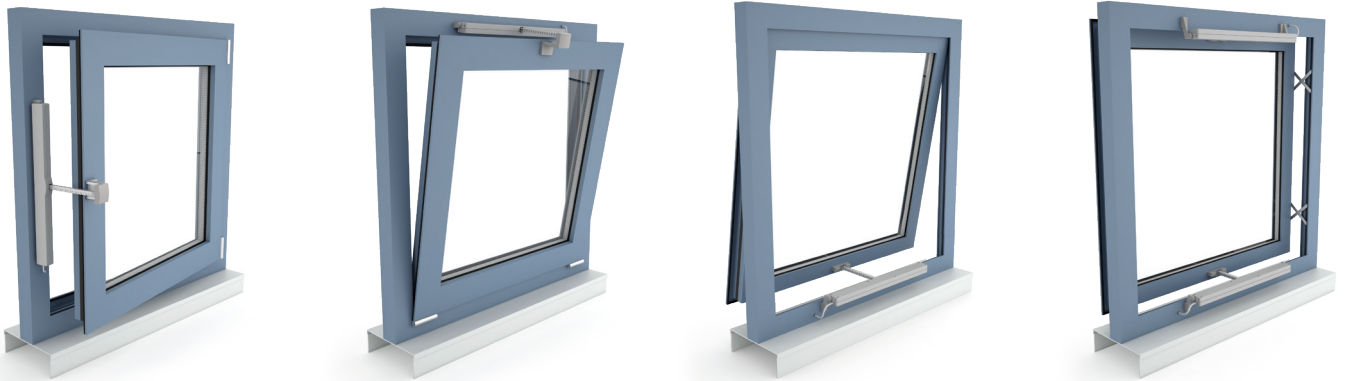

- » Mounted installation
- » Sash mounting
- » Frame mounting
- » Application force
- » Application tension
- » Trapezoidal application (ACB drives)

Installation example

2x VCD-0204-0350-1-ACB centic / window locking drive FRA 11

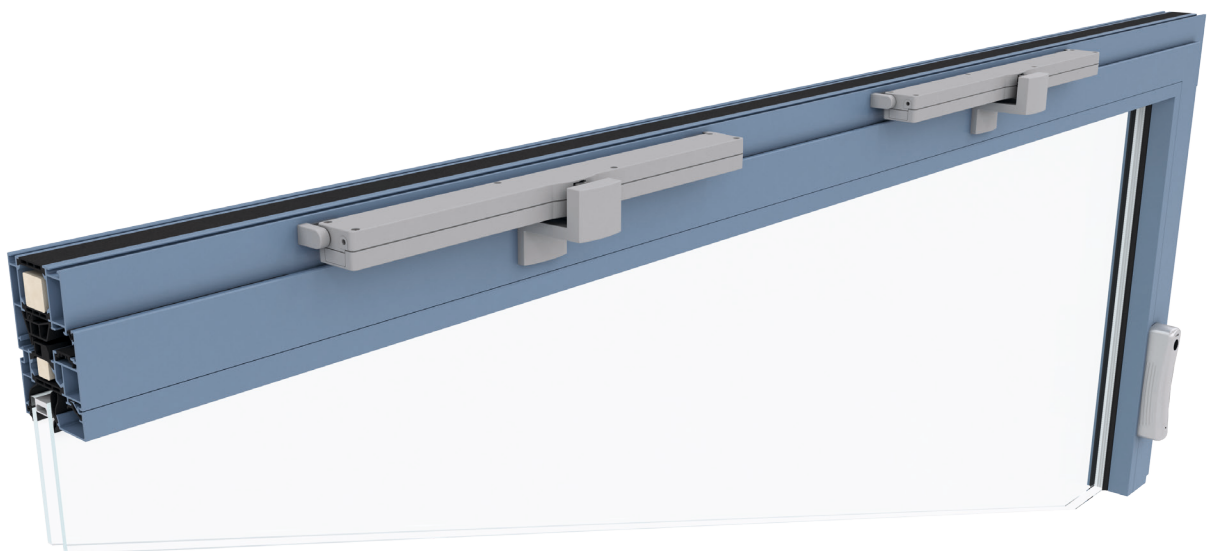

Brackets are not included and have to be ordered separately.

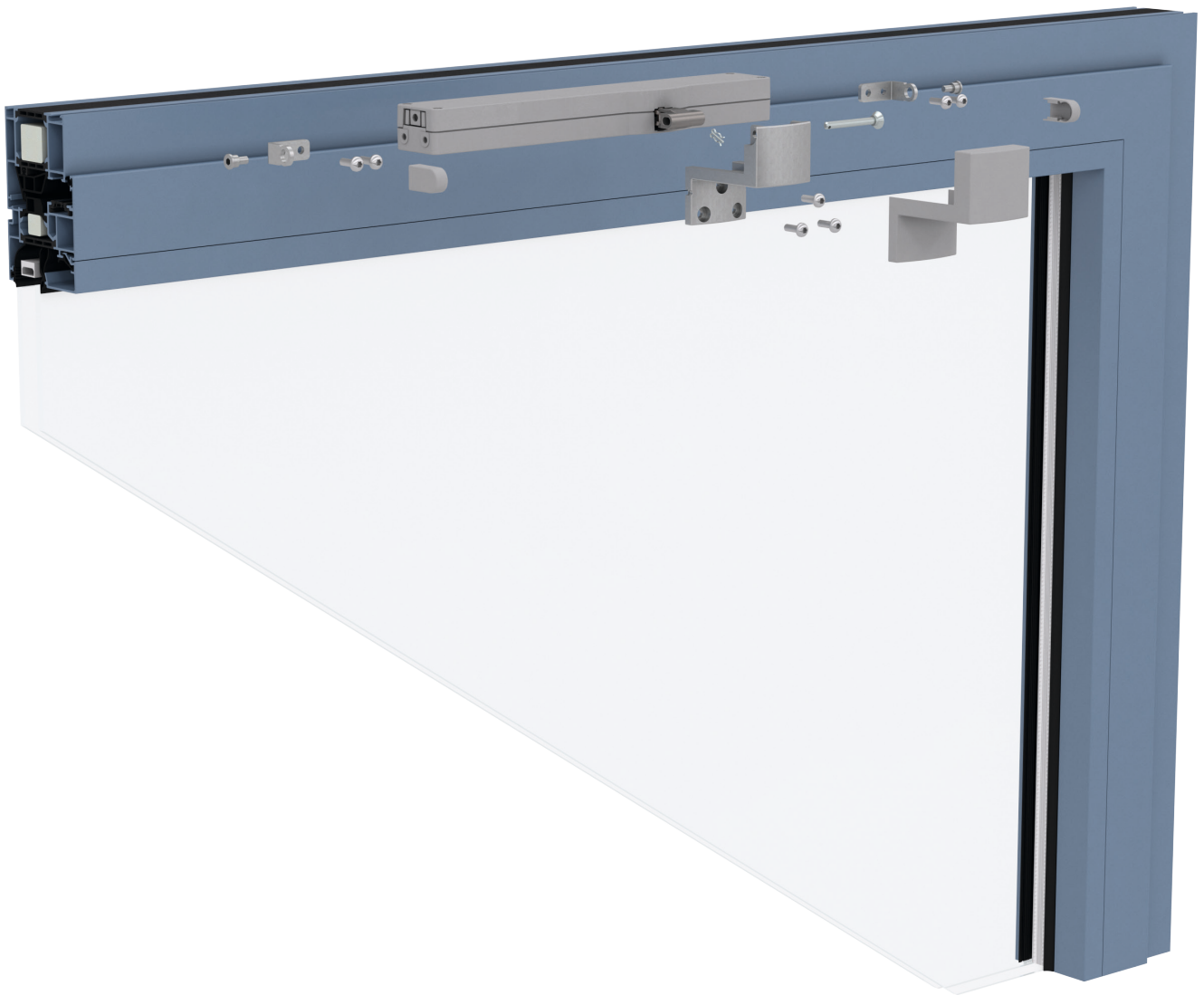

Bracket applications

Illustration provided as an example

Roof window,
outward opening

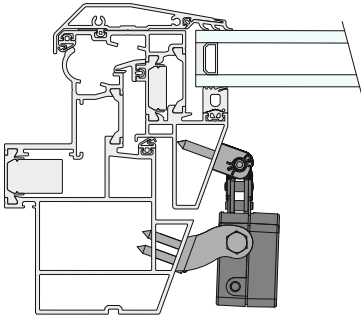

Façade windows,
nward opening

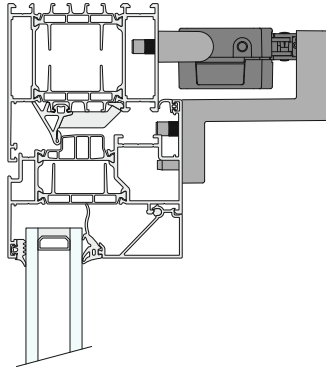

Façade windows,
outward opening

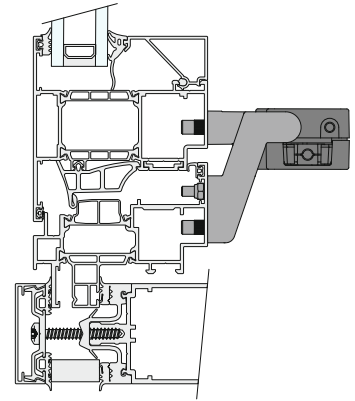

Roof windows

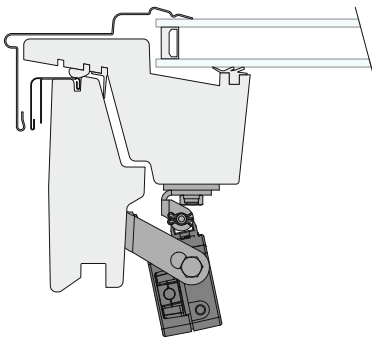

Universal bracket sets,
inward opening

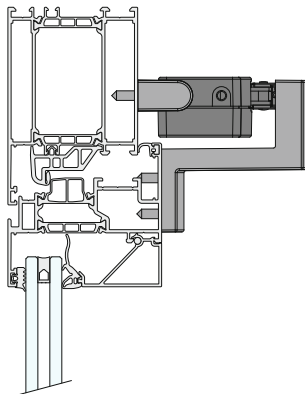

Universal bracket sets,
outward opening

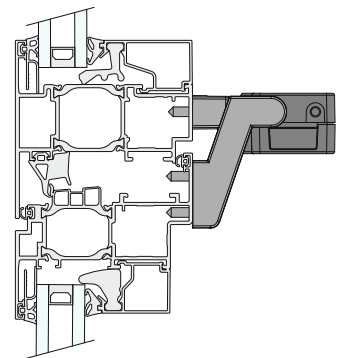

Legend

Product name

VCD - 0204 - 0250 - 1 - ACB - M1 - M

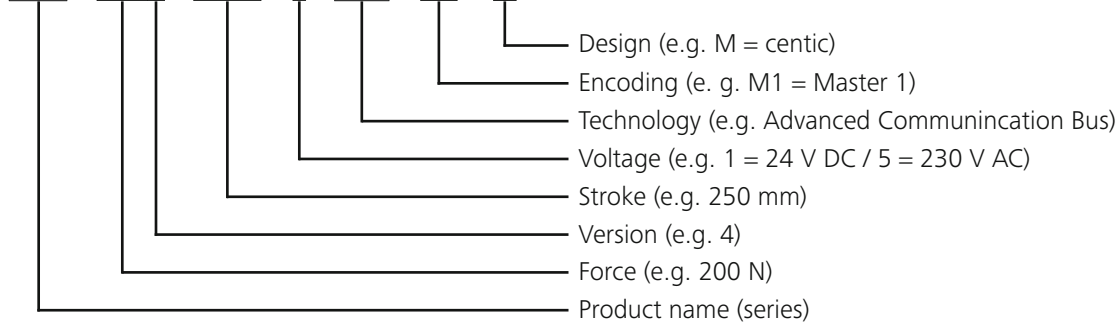

Notice / design



SHEV (Smoke and heat exhaust ventilation)



CNV (Controlled natural ventilation)









230 V AC



24 V DC

Options icons

-  Function programming
Option for customised configuring of drive parameters (e.g. stroke) via software and associated service tools for drives equipped with PLP, BSY or BSY+ electronics.
-  ACB (Advanced Communication Bus)
Enables direct bus communication between the controller and the drive for, for example, control with perfect positioning or drive feedback. Communication is via the open source Modbus protocol, and it enables the drive to be combined with an ACB-capable control panel or enables it to be directly connected to higher-level controllers such as a building management system.
-  BSY+ (synchronisation of drives)
In addition to providing the same synchronisation function as BSY, BSY+ enables different components in the window to communicate with each other. For example, the chain drives, during synchronous operation, or the window and locking drives (e.g. FRA 11 BSY+ or VLD-BSY+).
-  SGI signal (position reporting)
In combination with the D+H servo plug-in unit SE 622 or the BSY-gateway BSY-GW-024-010-U, the drives can be controlled with perfect positioning.
-  SKS (closing edge protection)
Drive option, which enables an anti-trap strip or presence detector to be connected directly to the drive (terminal resistor 5.6 kΩ).
-  Audible signal (corresponding to protection class)
AS2 corresponding to "Protection class 2" in accordance with ZVEI risk assessment through an audible warning signal in the "CLOSED" running direction. AS3 corresponding to "Protection class 3" in accordance with ZVEI risk assessment, in addition to AS2, stops the drive for 11 s with a remaining stroke of 28 mm.
-  End position message (OPEN / CLOSED)
Drive feedback via an integrated isolated switching contact. This happens if the chain / rack and pinion has moved completely out or in.

Overview of standards

DIN EN

DIN EN 60335-2-103

Requirements and test methods for drives for windows

UL

UL 325

This test standard defines, among other aspects, the requirements and test methods for electro-mechanical drives, which shall be used for ventilation purposes. The result of this test is a UR certificate.

Test centres / test symbols

Dekra

Approvals for the electric safety/security of products (drives and control panels) - particularly regarding Low Voltage Directive approvals for drives in accordance with the EN 60335-2-103 standard.

Underwriters Laboratory UL

Underwriters Laboratories (abbreviated UL) is an independent organisation which inspects and certifies products in terms of their safety. UL inspects products, components, materials and systems to see whether they conform to US and Canadian market requirements.

CCCF

The CCCF is a Chinese test institution which issues country-specific certificates on the basis of tests conducted at accredited Chinese test institutions for components or systems for SHEV systems in accordance with Chinese standards and laws.





D+H Mechatronic AG
Georg-Sasse-Straße 28-32
22949 Ammersbek
Germany

Phone: +49 40 60565 0
Fax: +49 40 60565 222
E-Mail: info@dh-partner.com



Your D+H service and sales partner:

WWW.DH-PARTNER.COM