



# Kaba smart key – Your clever allrounder

## Joining mechanics and electronics

Whether your system incorporates time recording, electronic or mechanical access control, the smart key is able to unify it all in one single access media.

Access rights of the RFID chip in the key head are checked by the electronic door components, whilst for mechanical locks, the reversible key is used. With the smart key, mechanical systems become more secure and IDs are no longer needed.

Daily use is really convenient due to easy handling and excellent reading capability. The smart key is an all-rounder handy to carry in any pocket thanks to its compact size.

## Better organisation and differentiation

The side of the smart key has a colour insert that can be easily exchanged. The choice of colours greatly simplifies the allocation of keys to different doors and owners.

## Flexible Integration

The integration concept is smart. It fits onto our existing clip keys, which means that the clip can be exchanged with little effort. Existing mechatronic access systems can be easily expanded or completely upgraded to the current RFID standards.

The smart key clip uses latest RFID technologies. Thus, the smart key is the universal access medium for all dormakaba systems, regardless of whether they are mechanical, mechatronic or electronic.

## Areas of application

Whether in large or small businesses, the smart key can be used anywhere. Ideally suited for combined access systems with mechanical and electronic lock elements in use.

## Advantages at a glance

### Less work

Only one access key to manage – thus less administrative work

### Seamless integration

Compatible with all dormakaba systems, be it mechanical, mechatronic or electronic

### Easy key upgrades

Existing clip keys can be upgraded or retrofitted with little effort

### Organisation and differentiation

Individual identification of key clips with easily exchangeable colour inserts

### Elegant design

Clip supplied in stylish black

### Future-proof

State-of-the-art security with the latest RFID technology

# Performance characteristics

## Versatility in use

The smart key opens cylinders and locks, grants access at readers and books transactions at terminals. Access rights are automatically updated during reading.

## Individual

The smart key can be adapted to all organisational requirements. Both sides of the clip have colour inserts which can be changed easily. They are available in six different colours.

## Investment protection

Existing Kaba clip keys can be easily retrofitted or upgraded. Your investments therefore continue to be useful. The smart key is compatible with all dormakaba systems (except the LargeKey).

## Seamless usage

In most systems, there are often ideal applications for mechanical, mechatronic and electronic solutions. The smart key combines mechanics, electronics and time management and offers an integrated system.

## One universal portfolio

dormakaba's product range includes additional, combinable products sharing the same elegant design and high quality.

## Flexible migration and scalable security

We offer the LEGIC Cross Standard Transponder (CTC) as a standard for the LEGIC prime environment. This means that LEGIC prime applications remain unchanged as they are. For future LEGIC advant applications (migration) upgrading is not necessary.

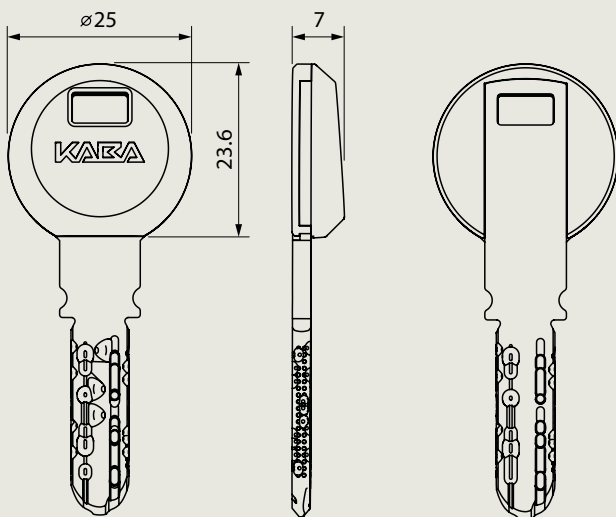

## dormakaba International Holding AG

Hofwissenstrasse 24  
CH-8153 Rümlang  
T. +41 848 85 86 87  
info.ch@dormakaba.com

www.dormakaba.com

## Technical features

### RFID technologies supported

- LEGIC CTC (prime/advant) 1kB/3kB
- LEGIC advant 4kB
- MIFARE DESFire 4kB
- MIFARE classic 1kB

### Types / Material / Dimensions

- Keys: Nickel silver
- User clip: black
- Programming master clip: gold or silver
- Clip: Polycarbonate
- Dimensions: 25 x 7 x 23.6 mm

### Key systems

- Kaba star
- Kaba 20
- Kaba gemini pluS
- Kaba quattro pluS
- Kaba expert pluS
- Kaba penta
- Kaba penta cross
- Kaba maTrix
- Kaba eco
- Kaba ace and their subsystems

### Colour coding

- Silver-grey, yellow, green, blue, violet, red

### Environmental conditions

- Temperature range: – 20 °C to + 70 °C
- Protection class: IP67
- Not suitable for prolonged submersion in water (e.g. bathing keys)

ATTENTION: Choking hazard for small children under 3 years of age due to swallowable small parts.

Further details and order information can be found in the respective dormakaba catalogues or system descriptions.

Subject to change without notice.  
Version 04/2019 © 2019 dormakaba.