

LDx-1-ACB / LDx-5-ACB

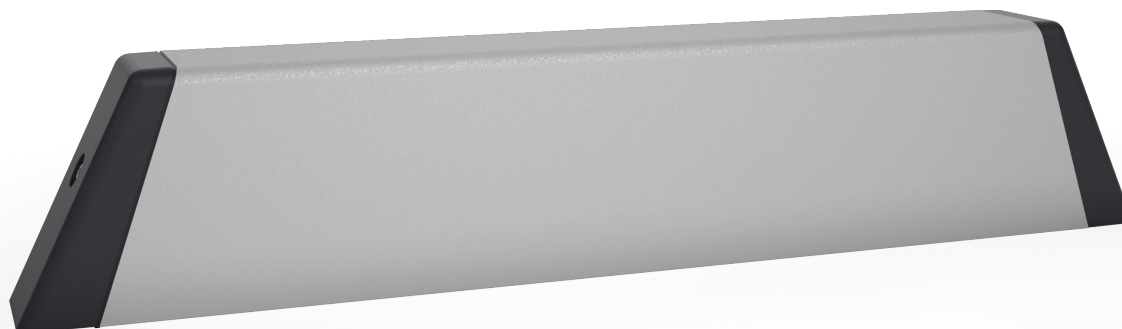
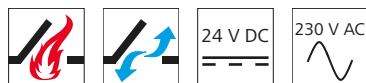

Performance features

- » Max. force of pressure and tensile force of 1400 N and 1800 N
- » Holding force of 5000 N for very large louvre windows
- » Louvre window drive can be adapted for all common louvre manufacturers (such as EuroLam, Fieger, HAHN, NACO, Schneider + Nölke)
- » Centrally supported driver position
- » Developed based on DIN EN 12101-2
- » Can be used for openings for smoke exhaust and for daily ventilation
- » With BSY+ motor and synchronised electronics controlled via microprocessor
- » With a sound pressure level of $L_p \leq 45$ dB(A), the drive is among the quietest of its class
- » Corrosion-protected drive components
- » Programmable drive functions and different drive parameters
- » Additional passive and active anti-trap protection system for the main closing edges with reversing function
- » Integrated ACB (Advanced Communication Bus) bus interface with Modbus RTU protocol
- » The drive is integrated directly via open bus communication through the ACB (Advanced Communication Bus), e.g. in a building management system

Approvals / Certificates

Find out about permission details from your D+H Partner.



Potential drive options

You can find the explanations for the icons on the last page.

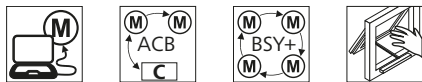

Dimensions

All specifications in mm

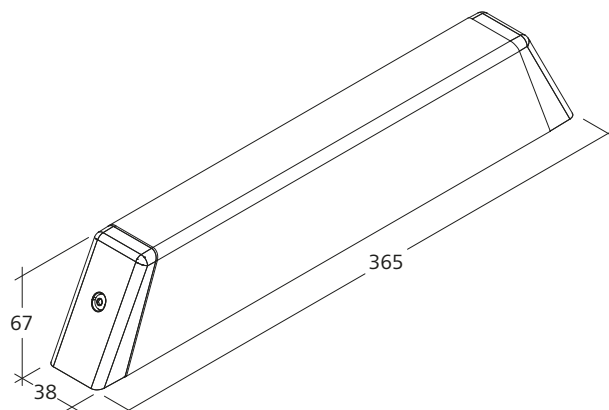

Technical data

	LDx-1400-1-ACB	LDx-1800-1-ACB	LDx-1400-5-ACB	LDx-1800-5-ACB
Supply	24 V DC / $\pm 20\%$ / 1.4 A	24 V DC / $\pm 20\%$ / 1.6 A	230 V AC / +10 % ... -15 % / 65 VA	230 V AC / +10 % ... -15 % / 75 VA
Force of pressure	1400 N	1800 N	1400 N	1800 N
Tensile force	1400 N	1800 N	1400 N	1800 N
Nominal locking force	5000 N			
Service life	20000 double strokes			
Stroke	36 - 90 mm			
OPEN running speed	2 mm/s			
CLOSED running speed	2 mm/s			
Type of protection	IP 40			
Emission sound pressure level	LpA \leq 45 dB(A)			
Temperature range	-5 °C ... +75 °C			
Fire resistance	B300 (30 min / 300 °C)			
Housing	Aluminium			
Surface	Anodized			
Colour	Special colour according to RAL			
Connection	Silicone cable			
W x H x D	365 x 67 x 38 mm			

Design

Type	Art. No.	Weight	Remark
LDx-1	24.021.10	1.50 kg	Variable equipment possible
LDx-5	24.021.15	1.50 kg	Variable equipment possible



HS "High speed"

In the case of SHEV, the high-speed function is used for reliably reaching the defined end position in 60 s. In daily ventilation mode, the drive runs quietly and quickly, as usual.



Function programming

Option for customised configuring of drive parameters (e.g. stroke) via software and associated service tools for drives equipped with PLP, BSY or BSY+ electronics.



BRV signal

Acknowledgement from the drive, via a control cable, to confirm that it has been completely extended or retracted. When used with the AT 41 and ERM 44 modules, this signal is sent to the central building control system, the modules themselves, or to the locking drive. The BRV signal is not isolated.



ACB (Advanced Communication Bus)

Enables direct bus communication between the controller and the drive for, for example, control with perfect positioning or drive feedback. Communication is via the open source Modbus protocol, and it enables the drive to be combined with an ACB-capable control panel or enables it to be directly connected to higher-level controllers such as a building management system.



BSY+ (synchronisation of drives)

In addition to providing the same synchronisation function as BSY, BSY+ enables different components in the window to communicate with each other. For example, the chain drives, during synchronous operation, or the window and locking drives (e.g. FRA 11 BSY+ or VLD-BSY+).



SGI signal (position reporting)

In combination with the D+H servo plug-in unit SE 622 or the BSY-gateway BSY-GW-024-010-U, the drives can be controlled with perfect positioning.



SKS (closing edge protection)

Drive option, which enables an anti-trap strip or presence detector to be connected directly to the drive (terminal resistor 5.6 kΩ).



Audible signal (corresponding to protection class)

AS2 corresponding to "Protection class 2" in accordance with ZVEI risk assessment through an audible warning signal in the "CLOSED" running direction. AS3 corresponding to "Protection class 3" in accordance with ZVEI risk assessment, in addition to AS2, stops the drive for 11 s with a remaining stroke of 28 mm.



End position message (OPEN / CLOSED)

Drive feedback via an integrated isolated switching contact. This happens if the chain / rack and pinion has moved completely out or in.



TM tandem connecting shaft

Available as an option for rack and pinion drives. The drives are mechanically coupled with the rack and pinion slave units (ZM) with connecting shafts (VW).



SBD side bow chain

Drive chain with rigid backing, bends in the direction of the hinge. Drive is fixed in place (not rotatable).



SBU side bow chain

Drive chain with rigid backing, bends in the direction of the hinge. Drive is fixed in place (not rotatable).



WS (use in swimming pool)

Available as an option for rack and pinion drives to make them suitable for use in swimming pools. The drive is equipped with an A4 rack and pinion, A4 eyebolt and a gearbox with hardened stainless steel pinion.



W (use outdoors)

Available as an option for rack and pinion drives to make them suitable for outdoor use. The drive is equipped with a pressure release vent (depending on installation), condensation protective coating on the electronics and a gearbox with hardened stainless steel pinion.