

ZA-1000-1-ACB-HS

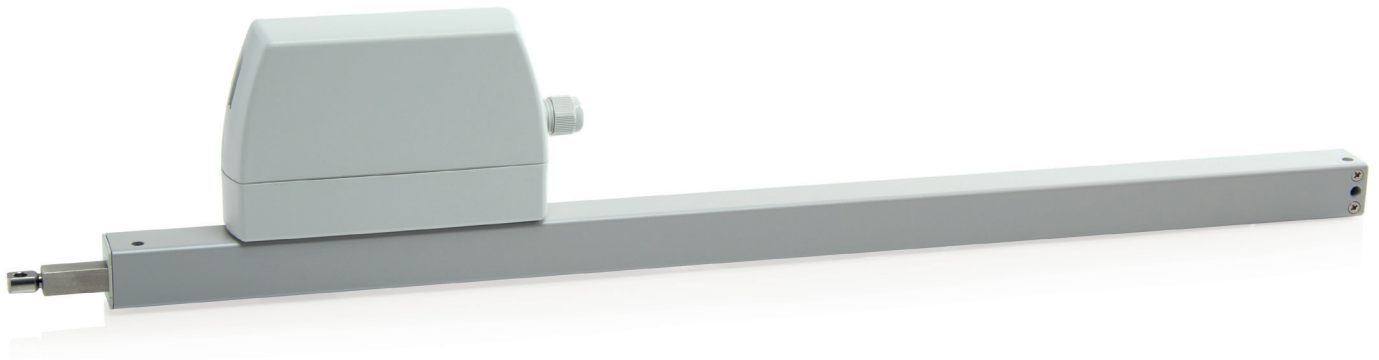

Performance features

- » Can be used for openings for smoke exhaust; D+H Euro SHEV in accordance with EN 12101-2; and for daily ventilation
- » With integrated BSY+ motor and synchronised electronics controlled via microprocessor
- » High-speed function (HS) for especially fast opening windows in case of fire (SHEV)
- » Option of up to 8 drives in one synchronous group
- » Option of cable infeed above and below
- » Drive unit can be changed from left to right
- » Programmable drive functions and different drive parameters
- » Running speed in CLOSED direction decreases to 5 mm/s (passive closing edge protection)
- » Time-controlled reversing when an obstacle is detected in the CLOSED direction (active closing edge protection)
- » Integrated ACB (Advanced Communication Bus) bus interface with Modbus protocol
- » The drive is integrated directly via open bus communication through the ACB (Advanced Communication Bus), e.g. in a building management system

Potential drive options

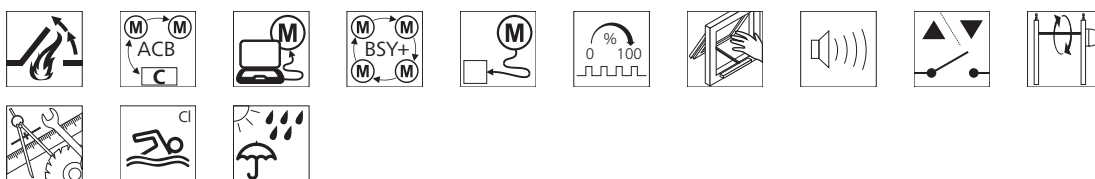

You can find the explanations for the icons on the last page

Pressure load diagram

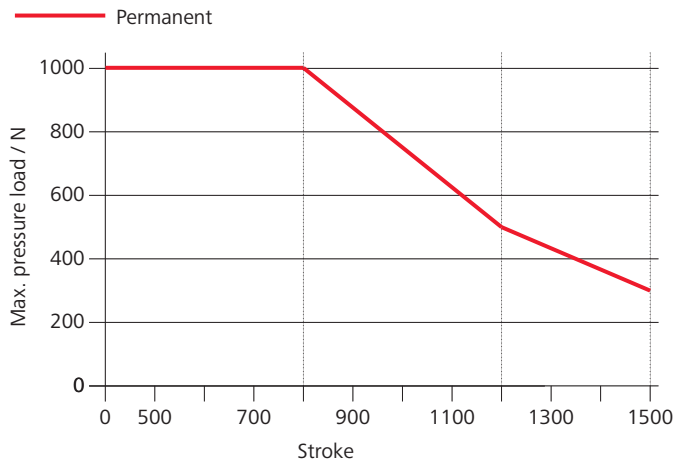

Dimensions

All specifications in mm

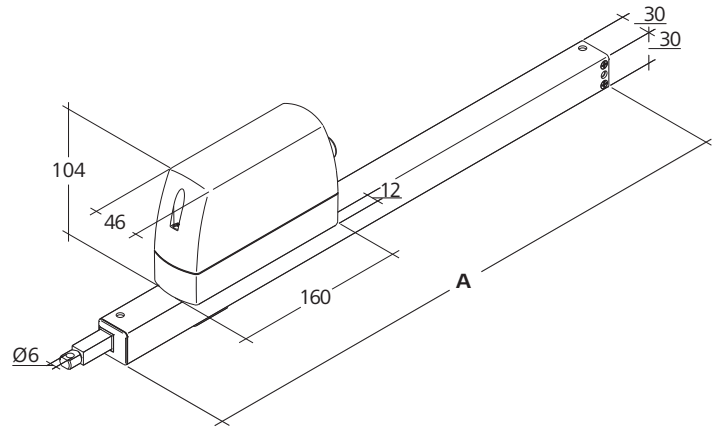

Technical data

Supply	24 V DC / ±15 % / 2.2 A
Duty cycle	30 %
Force of pressure	1000 N
Tensile force	1000 N
Nominal locking force	1100 N
Service life	20000 double strokes *
OPEN running speed	7 mm/s
OPEN running speed - HS	17 mm/s
CLOSED running speed	7 mm/s
Type of protection	IP 65
Emission sound pressure level	LpA ≤ 60,5 dB(A)
Temperature range	-5 °C ... +75 °C
Fire resistance	B300 (30 min / 300 °C)
Housing	Aluminium / Polycarbonate
Surface	Powder-coated
Colour	White aluminium (~ RAL 9006)
Connection	2.5 m silicone cable

* For vertical use, please consult with D+H Sales!

Approvals / Certificates

Find out about permission details from your D+H Partner



Design

Type	Art. No.	Stroke	Dimension A	Weight	Remark
ZA-1000-0600-1-ACB M1-R HS	27.013.05	600 mm	762 mm	2.10 kg	
ZA-1000-0600-1-ACB M2-R HS	27.013.20	600 mm	762 mm	2.10 kg	
ZA-1000-0600-1-ACB S1-L HS	27.013.35	600 mm	762 mm	2.10 kg	
ZA-1000-0800-1-ACB M1-R HS	27.013.10	800 mm	962 mm	2.50 kg	Without holes on bottom, only for topside mounting
ZA-1000-0800-1-ACB M2-R HS	27.013.25	800 mm	962 mm	2.50 kg	Without holes on bottom, only for topside mounting
ZA-1000-0800-1-ACB S1-L HS	27.013.40	800 mm	962 mm	2.50 kg	Without holes on bottom, only for topside mounting
ZA-1000-1000-1-ACB M1-R HS	27.013.15	1000 mm	1162 mm	2.70 kg	Without holes on bottom, only for topside mounting
ZA-1000-1000-1-ACB M2-R HS	27.013.30	1000 mm	1162 mm	2.70 kg	Without holes on bottom, only for topside mounting
ZA-1000-1000-1-ACB S1-L HS	27.013.45	1000 mm	1162 mm	2.70 kg	Without holes on bottom, only for topside mounting
ZA-1-ACB	27.011.00				Variable equipment possible

Brackets are not included and have to be ordered separately.



HS "High-Speed"

In the case of SHEV, the high-speed function is used for reliably reaching the defined end position in 60 s. In daily ventilation mode, the drive runs quietly and quickly, as usual.



Function programming

Option for customised configuring of drive parameters (e.g. stroke) via software and associated service tools for drives equipped with PLP, BSY or BSY+ electronics.



BRV signal

Acknowledgement from the drive, via a control cable, to confirm that it has been completely extended or retracted. When used with the AT 41 and ERM 44 modules, this signal is sent to the central building control system, the modules themselves, or to the lock drive. The BRV signal is not isolated.



ACB (Advanced Communication Bus)

Enables direct bus communication between the controller and the drive for, for example, control with perfect positioning or drive feedback. Communication is via the open source Modbus protocol, and it enables the drive to be combined with an ACB-capable control panel or enables it to be directly connected to higher-level controllers such as a building management system.



BSY+ (synchronisation of drives)

In addition to providing the same synchronisation function as BSY, BSY+ enables different components in the window to communicate with each other. For example, the chain drives, during synchronous operation, or the window and lock drives (e.g. FRA 11 BSY+ or VLD-BSY+).



SGI signal (position reporting)

In combination with the D+H servo plug-in unit SE 622, the drives can be controlled with perfect positioning.



SKS (closing edge protection)

Drive option, which enables an anti-trap strip or presence detector to be connected directly to the drive (terminal resistor 5.6 kΩ).



Audible signal (corresponding to protection class)

AS2 corresponding to "Protection class 2" in accordance with ZVEI risk assessment through an audible warning signal in the "CLOSED" running direction. AS3 corresponding to "Protection class 3" in accordance with ZVEI risk assessment, in addition to AS2, stops the drive for 11 s with a remaining stroke of 28 mm.



End position message (OPEN / CLOSED)

Drive feedback via an integrated isolated switching contact. This happens if the chain / rack and pinion has moved completely out or in.



Mechanical adjustment

Drive option for adjusting the overall length or design (e.g.: centred chain outlet).



TM tandem connecting shaft

Available as an option for rack and pinion drives. The drives are mechanically coupled with the rack and pinion slave units (ZM) with connecting shafts (VW).



WS (use in swimming pool)

Available as an option for rack and pinion drives to make them suitable for use in swimming pools. The drive is equipped with an A4 rack and pinion, A4 eyebolt and a gearbox with hardened stainless steel pinion.



W (use outdoors)

Available as an option for rack and pinion drives to make them suitable for outdoor use. The drive is equipped with a pressure release vent (depending on installation), condensation protective coating on the electronics and a gearbox with hardened stainless steel pinion.