

# ENDURA® TWIST

Decentralized ventilation solution with heat recovery

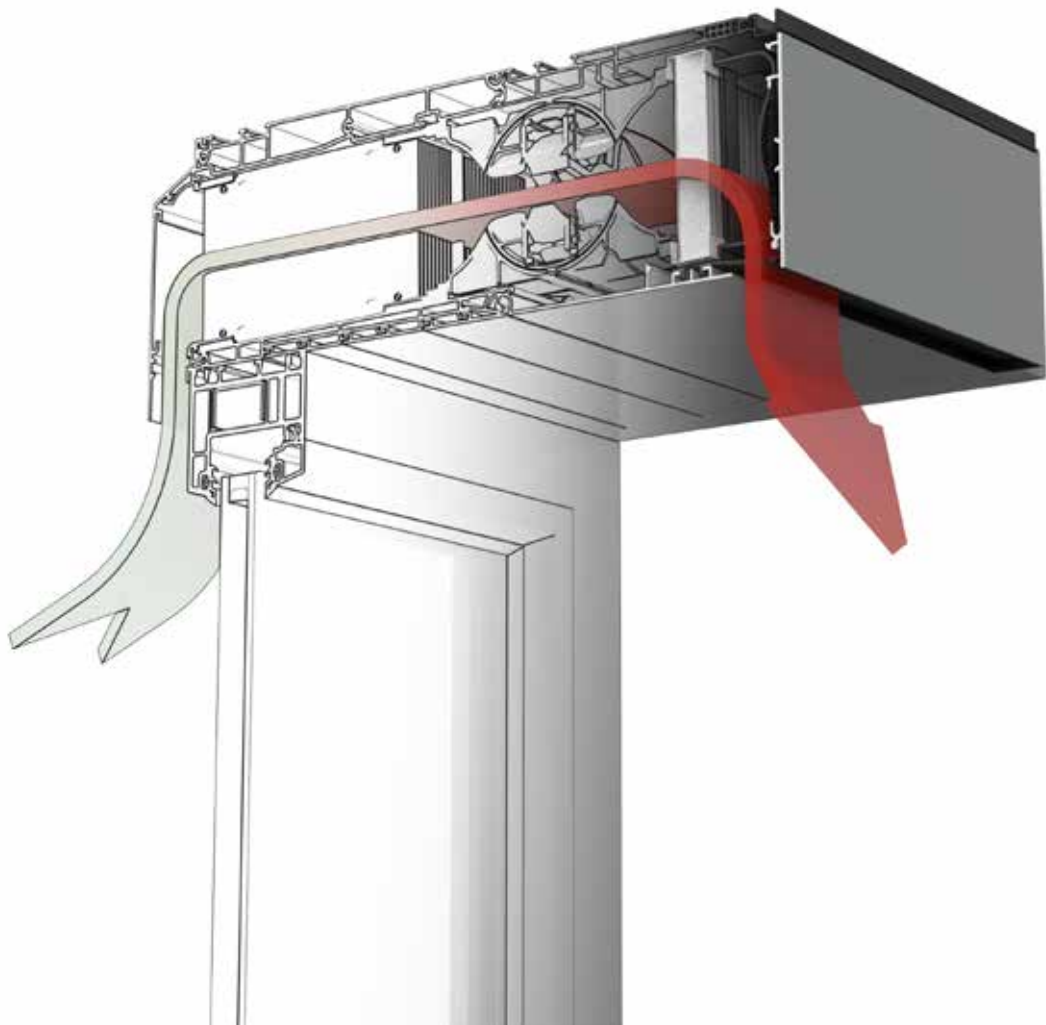

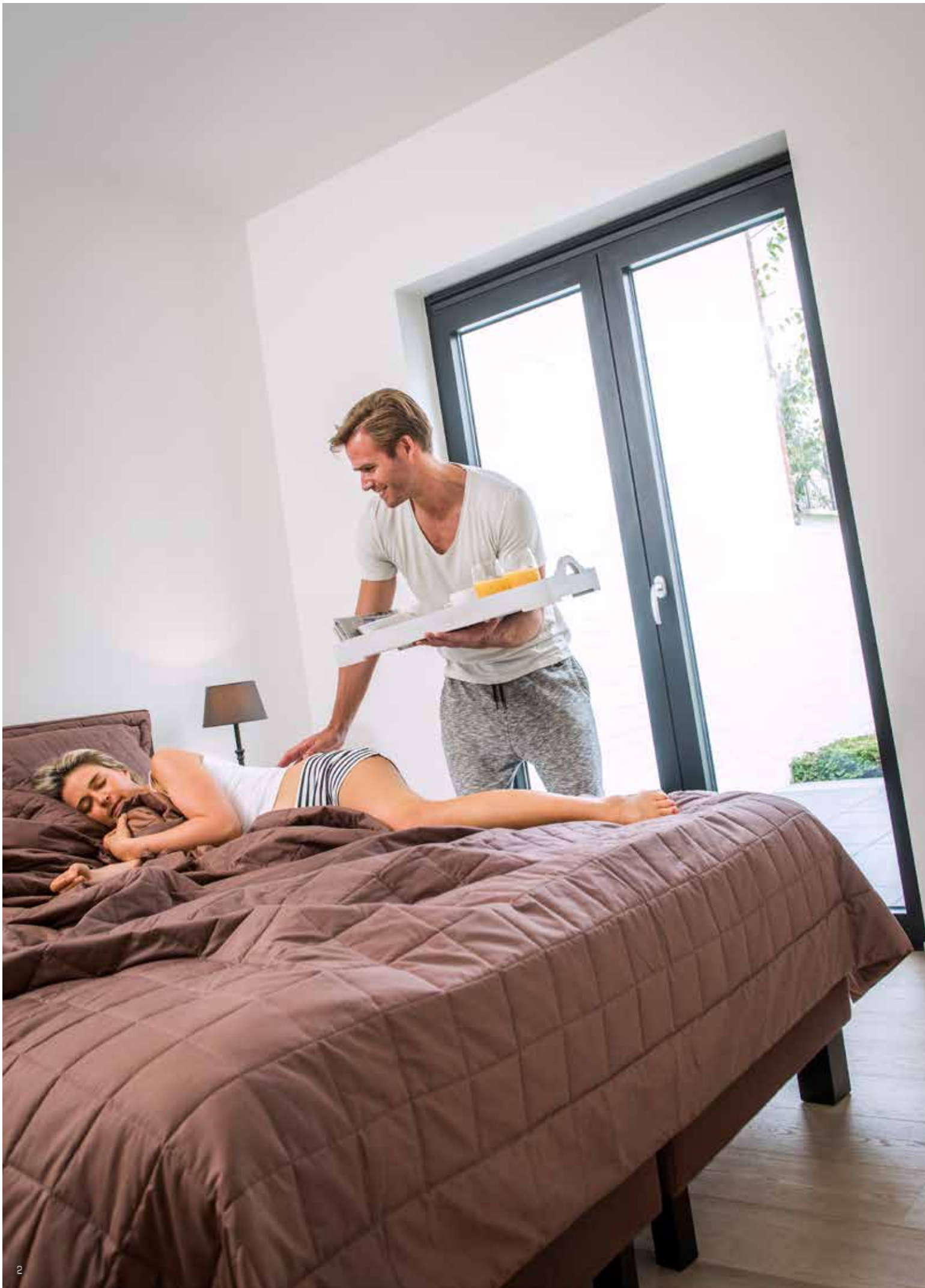

# HEALTHY LIVING

Our indoor climate is often polluted by unhealthy air, which has a major impact on the quality and comfort of our daily lives: too much moisture in our homes can lead to molds, while polluted air with too much CO<sub>2</sub> will cause headaches, respiratory problems, allergies, sleep disorders and concentration problems.

Natural ventilation ensures a healthy living climate.

A continuous smart supply of fresh air creates a comfortable indoor climate, without unnecessary energy losses.

The quiet, decentralized Endura Twist with heat recovery offers a maximum comfort with a minimal consumption and can be tailored to the lifestyle of its users!

We're constantly surrounded by noises (traffic, industry, etc.) from the rushed society we live in.

A good night's rest is an important condition for a healthy, high-quality and stress-free life. The silent Endura Twist provides us with the healthy fresh air we need and blocks out disturbing noises at the same time.

## CO<sub>2</sub>-MONITOR

The CO<sub>2</sub>-concentration is an important indicator of good indoor air quality and can be measured with the Renson® CO<sub>2</sub>-monitor. Air quality is expressed in particles CO<sub>2</sub> per million air particles (ppm = parts per million).

The assumed maximum value is 1200 ppm CO<sub>2</sub>. If it exceeds this value, people could suffer from headaches, drowsiness, fatigue or irritation of the mucous membranes. Research has also shown that if the CO<sub>2</sub> concentration exceeds 1000 ppm, it decreases the ability to concentrate.

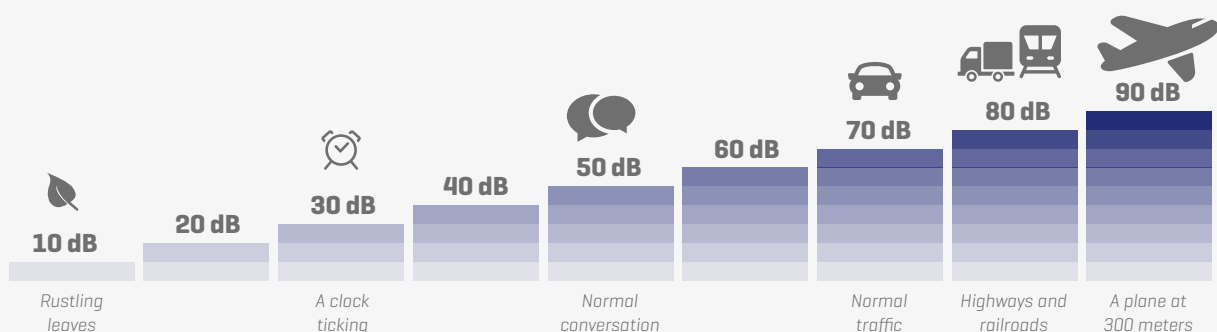

# HIGH EFFICIENCY, LOW ENERGY BILL

## COMFORTABLE, ENERGY-EFFICIENT AND ECONOMICAL

The heat of the used indoor air won't be lost during cold winter months, but will optimally preheat the incoming fresh air. Heat recovery implies an immediate decrease in heating costs and reduces our ecological footprint.

Thanks to its innovative technology, the **economical** and **highly efficient** Endura Twist can boast with an extremely economical consumption, with a thermal efficiency up to 80% and an A+ Ecolabel\*.

\* With demand control





**Endura® Twist**

- Vertical installation
- Can be perfectly combined with screens (i.e. Fixscreen 100<sup>EVO</sup> Slim) or shutters
- Continuous supply and extraction of air
- Up to 80% heat recovery

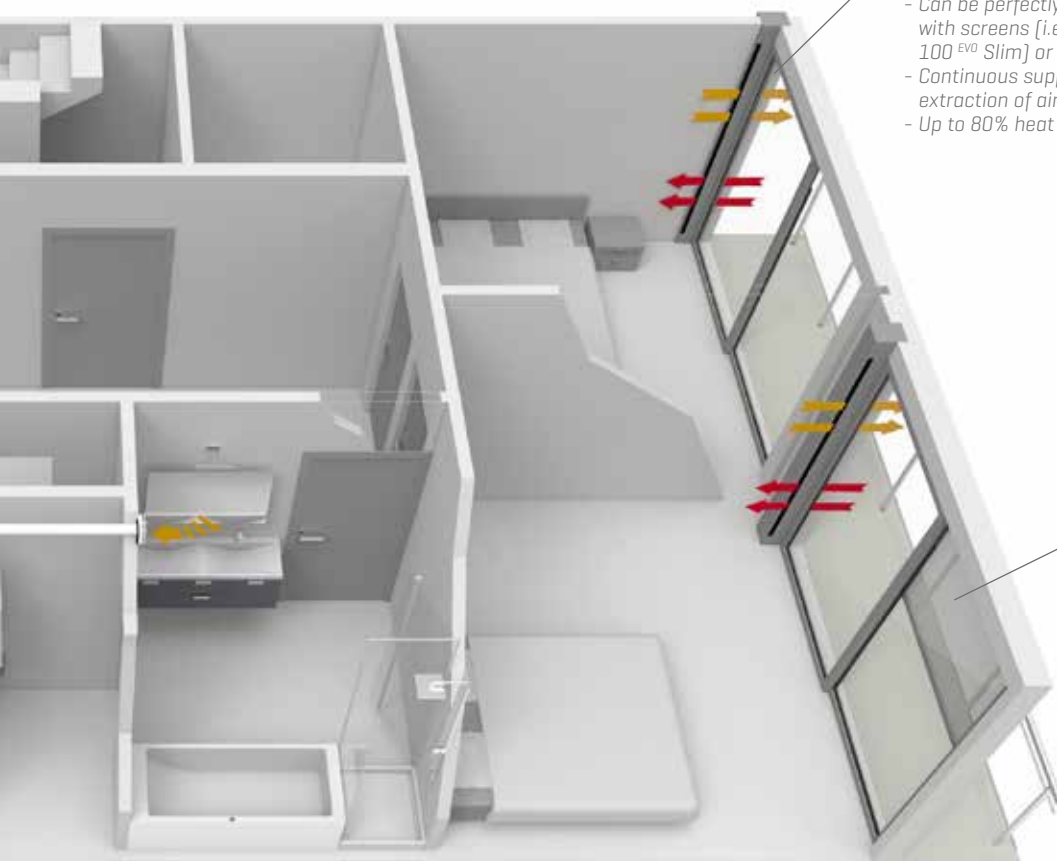

**Fixscreen® 100<sup>EVO</sup> Slim**

- Sun protection
- Hidden installation
- Wind tight thanks to ingenious zip system



# INTELLIGENT TECHNOLOGY

## DECENTRALIZED VENTILATION SYSTEM WITH HEAT RECOVERY

The Endura Twist stores the heat of the indoor air in the regenerators. As the fans turn every 30 seconds, the regenerators pass the stored heat to the fresh incoming air and a pleasant, preheated air is blown into the room.

Due to the continuous cyclic operation of the alternating fans, which ensures a constant air supply and air extraction, the customer can enjoy an optimal air quality at any time. The quick installation without ducts and easy maintenance make the Endura Twist ideal for both new-builds as renovations.



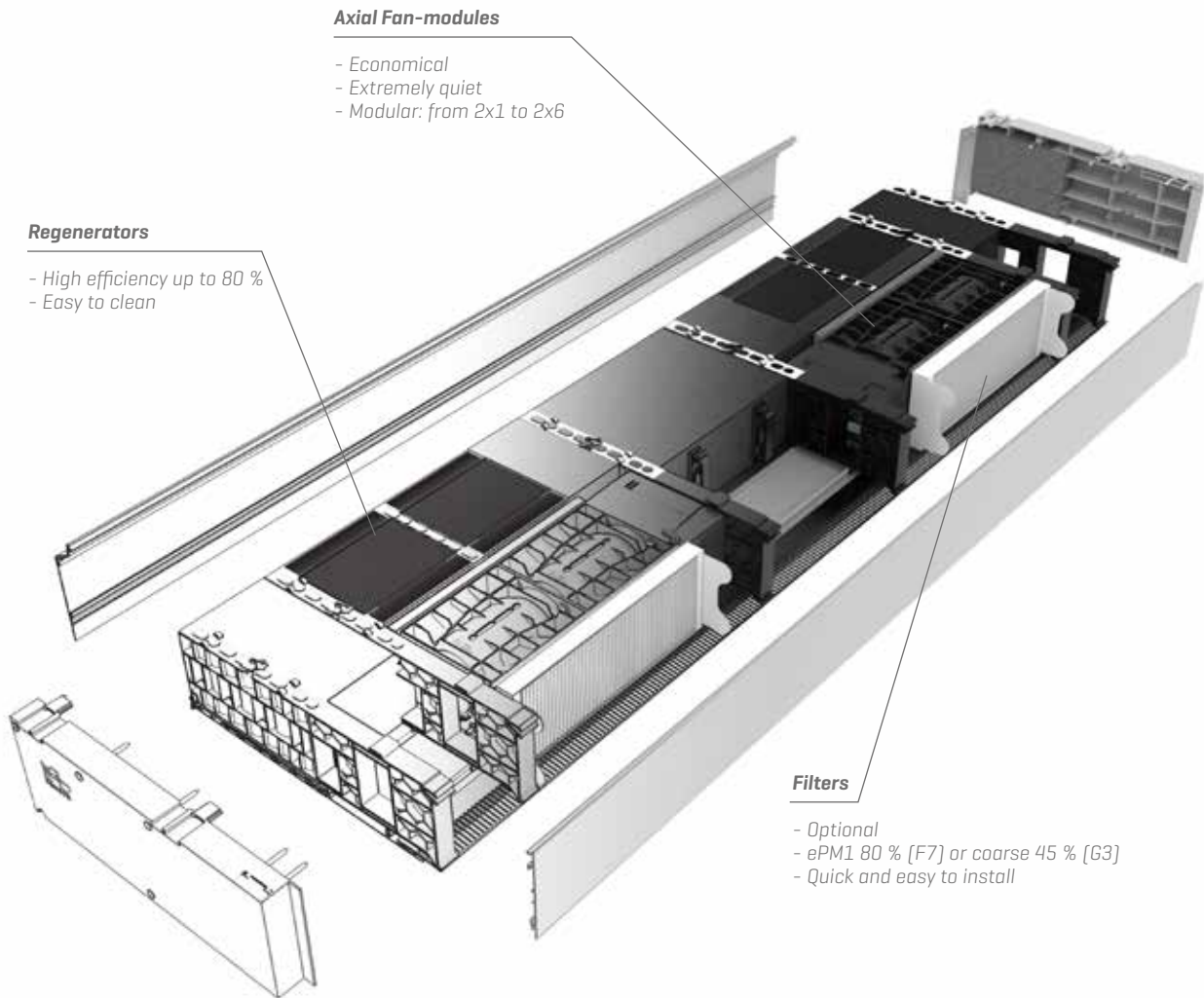

## FILTERS

In order to keep pollen, dust and pollution out, the Endura Twist can be equipped with efficient filters [coarse 45% [G3] or ePM1 80% [F7]] which are very easy and quick to replace. The appliance itself indicates when the filters should be replaced, therefore the customer can always enjoy healthy and clean air without any worries.



# A VENTILATION SYSTEM FOR ALL SEASONS

During the cool nights of a hot summer, the system automatically switches to **bypass mode** due to the integrated temperature sensors: the Endura Twist blows fresh outdoor air in, extracts hot indoor air without any heat recovery and in doing so, it freshens the house.

To prevent overheating, the vertical Endura Twist can be combined with an integrated sun protection screen or shutters. The combination of a comfortable ventilation with a beautiful and efficient sun protection provides the perfect aesthetic solution for beautiful warm summers.





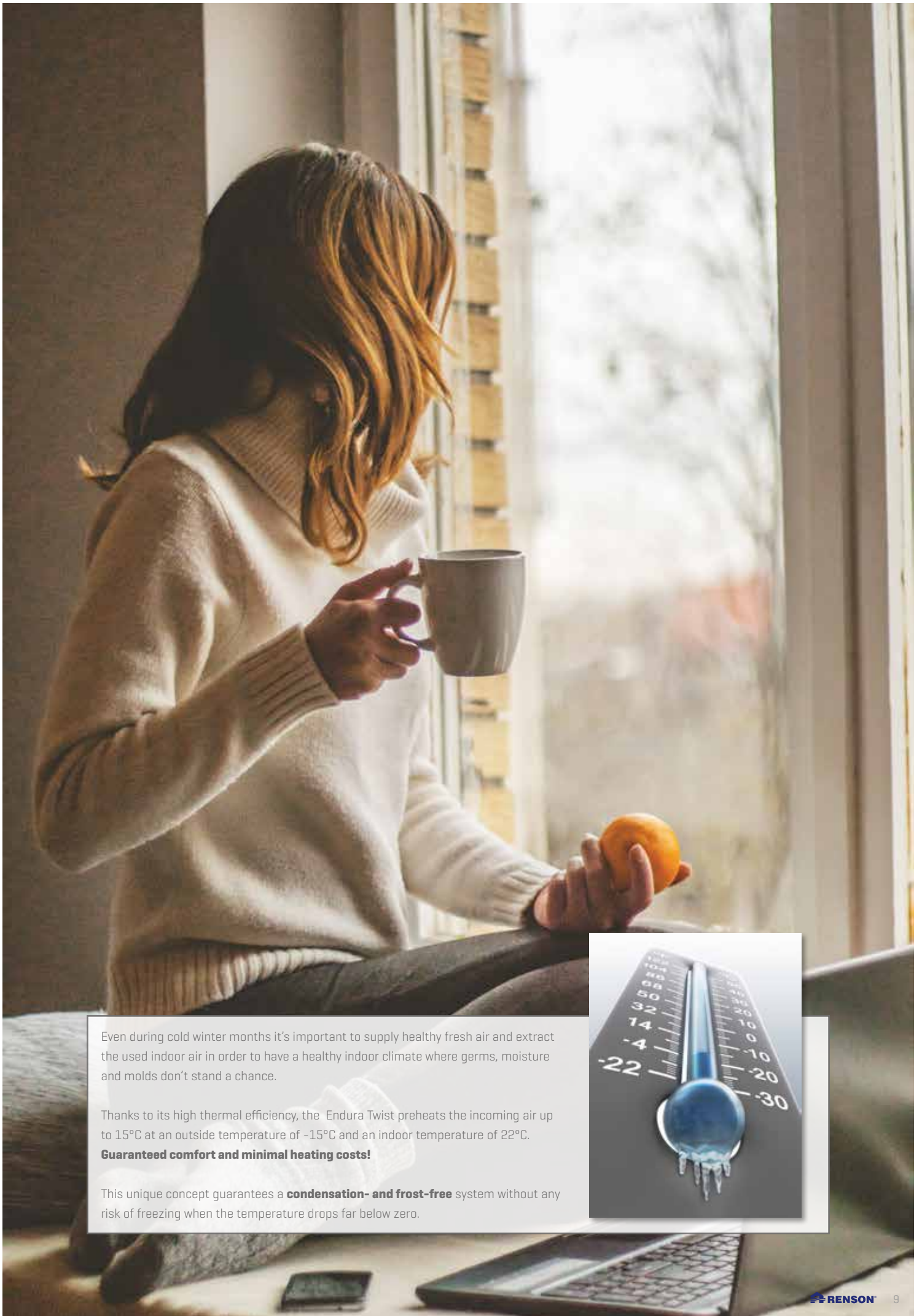

Even during cold winter months it's important to supply healthy fresh air and extract the used indoor air in order to have a healthy indoor climate where germs, moisture and molds don't stand a chance.

Thanks to its high thermal efficiency, the Endura Twist preheats the incoming air up to 15°C at an outside temperature of -15°C and an indoor temperature of 22°C.

**Guaranteed comfort and minimal heating costs!**

This unique concept guarantees a **condensation- and frost-free** system without any risk of freezing when the temperature drops far below zero.





# INSTALLATION MODELS

There is a perfect Endura Twist for every type of home!  
Considering the installation possibilities, the device can be placed on top or next to the window, depending on the customer's wishes.

## VERTICAL

The vertical Endura Twist is placed next to the window and is a beautiful aesthetic solution with a perfect interior finish.  
The air supply can be directed towards the wall or the window, depending on your preference.

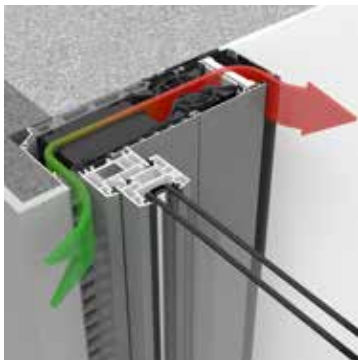

Air supply towards the window

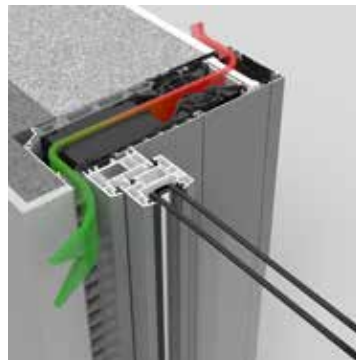

Air supply towards the wall

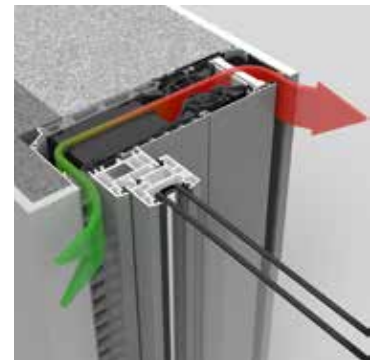

Air supply towards the window + plastered

## HORIZONTAL

The horizontal Endura Twist is placed on top of the window and directs the air supply up or down. The Endura Twist can be placed completely hidden behind the façade, which makes the device barely visible on the outside.



Downwards air supply



Downwards air supply + plastered



Upwards air supply



# OPERATIONS

## TOUCHDISPLAY

The TouchDisplay completely aligns the Endura Twist to the rhythm of its users. The built-in CO<sub>2</sub> sensor constantly monitors the air quality and automatically controls the unit to ensure an optimal and comfortable air quality with as little energy consumption as possible. The TouchDisplay is very easy to install thanks to its wireless communication with the Endura Twist.



## BUTTON CONTROL

The wireless button control is a simple control with a button cell battery. This control doesn't require a power supply, making it extremely easy to install as you can hang it anywhere you want.



## BUILDING MANAGEMENT SYSTEM

The Endura Twist can be controlled by a building management system. The combination can be made of a control by the building management system with another mean of control: for example, employees can manage the device during working hours while after hours, the building management system takes over.

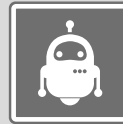

The **Automatic mode** allows the customer to tailor the Endura Twist to his life. The unit runs completely automatically according to the set time schedule. The desired ventilation schedule can be set per day/per week/per weekend/far each hour of the day.  
*[Automatic mode only available with TouchDisplay and building management system]*



The **Silent mode** ensures an extremely quiet, noiseless operation.



In hot summer months, the device detects the need for cooling during cool nights. The **automatic bypass** switches off the heat recovery, blows cooler air in and extracts the warm indoor air.



In order to never compromise the comfort of its users, the Endura Twist automatically closes when it detects extreme weather conditions (such as heavy winds or temperatures below -19° C).



With the boost function, the customer can run the fans at full speed. By switching the device to the highest level, the room will be aired in no time!

# A MODULAR SYSTEM

Endura Twist has a variable length: from **min. 750 mm to max. 6000 mm**.  
The unit can be used as well for small windows as for large glass surfaces

Depending on the required air flow, the number of fans can be customized from 2x1 to 2x6 modules.



## MODELS

<b>Endura Twist 2x1</b> 2 x 1 fan - $Q_{nom}$ 12 m <sup>3</sup> /h	
<b>Endura Twist 2x2</b> 2 x 2 fans - $Q_{nom}$ 24 m <sup>3</sup> /h	
<b>Endura Twist 2x3</b> 2 x 3 fans - $Q_{nom}$ 36 m <sup>3</sup> /h	
<b>Endura Twist 2x4</b> 2 x 4 fans - $Q_{nom}$ 48 m <sup>3</sup> /h	
<b>Endura Twist 2x5</b> 2 x 5 fans - $Q_{nom}$ 60 m <sup>3</sup> /h	
<b>Endura Twist 2x6</b> 2 x 6 fans - $Q_{nom}$ 72 m <sup>3</sup> /h	

$Q_{nom}$  = 50%  $Q_{max}$  with coarse 45 % filter (G3)

# TECHNICAL INFORMATION

## TECHNICAL SPECIFICATIONS: with coarse 45% [G3] filter / with ePM1 80% [F7] filter

Endura Twist							
Number of fans		2 x 1	2 x 2	2 x 3	2 x 4	2 x 5	2 x 6
Coarse 45%	Q <sub>min</sub> [25%]	6 m <sup>3</sup> /h	12 m <sup>3</sup> /h	18 m <sup>3</sup> /h	24 m <sup>3</sup> /h	30 m <sup>3</sup> /h	36 m <sup>3</sup> /h
	Q <sub>nom</sub> [50%]	12 m <sup>3</sup> /h	24 m <sup>3</sup> /h	36 m <sup>3</sup> /h	48 m <sup>3</sup> /h	60 m <sup>3</sup> /h	72 m <sup>3</sup> /h
	Q <sub>max</sub> [100%] 13,8V	24 m <sup>3</sup> /h	48 m <sup>3</sup> /h	72 m <sup>3</sup> /h	96 m <sup>3</sup> /h	120 m <sup>3</sup> /h	144 m <sup>3</sup> /h
ePM1 80%	Q <sub>min</sub> [25%]	4,9 m <sup>3</sup> /h	9,8 m <sup>3</sup> /h	14,7 m <sup>3</sup> /h	19,6 m <sup>3</sup> /h	24,5 m <sup>3</sup> /h	29,4 m <sup>3</sup> /h
	Q <sub>nom</sub> [50%]	9,8 m <sup>3</sup> /h	19,6 m <sup>3</sup> /h	29,4 m <sup>3</sup> /h	39,2 m <sup>3</sup> /h	49 m <sup>3</sup> /h	58,9 m <sup>3</sup> /h
	Q <sub>max</sub> [100%] 13,8V	19,6 m <sup>3</sup> /h	39,2 m <sup>3</sup> /h	58,8 m <sup>3</sup> /h	78,4 m <sup>3</sup> /h	98 m <sup>3</sup> /h	117,7 m <sup>3</sup> /h
Thermal efficiency level [EN13141-8]		max. 80%					
Sound reduction [ISO 10140-2] D <sub>n,e,w</sub> [C;C <sub>tr</sub> ] in open position		40 [0;-3] dB					
Sound reduction [ISO 10140-2] D <sub>n,e,w</sub> [C;C <sub>tr</sub> ] in closed position		50,6 [-3;-7] dB					
Sound generation [ISO 3741:2010] L <sub>p</sub> , measured at 2 m distance from the window vent							
Coarse 45%	Q <sub>min</sub>	18,0 dB[A]	21,0 dB[A]	22,8 dB[A]	24,0 dB[A]	25,0 dB[A]	25,8 dB[A]
	Q <sub>nom</sub>	34,2 dB[A]	37,2 dB[A]	39,0 dB[A]	40,2 dB[A]	41,2 dB[A]	42,0 dB[A]
	Q <sub>max</sub>	39,9 dB[A]	42,9 dB[A]	44,7 dB[A]	45,9 dB[A]	46,9 dB[A]	47,7 dB[A]
ePM1 80%	Q <sub>min</sub>	19,6 dB[A]	22,6 dB[A]	24,4 dB[A]	25,6 dB[A]	26,6 dB[A]	27,4 dB[A]
	Q <sub>nom</sub>	36,7 dB[A]	39,7 dB[A]	41,5 dB[A]	42,7 dB[A]	43,7 dB[A]	44,5 dB[A]
	Q <sub>max</sub>	42,7 dB[A]	45,7 dB[A]	47,5 dB[A]	48,7 dB[A]	49,7 dB[A]	50,5 dB[A]
Power Consumption							
Coarse 45%	Q <sub>min</sub>	2,7 W	3,8 W	4,8 W	5,9 W	6,9 W	8,0 W
	Q <sub>nom</sub>	3,6 W	5,5 W	7,4 W	9,4 W	11,3 W	13,2 W
	Q <sub>max</sub>	6,0 W	10,4 W	14,7 W	19,1 W	23,4 W	27,7 W
ePM1 80%	Q <sub>min</sub>	2,8 W	3,9 W	5,1 W	6,2 W	7,3 W	8,4 W
	Q <sub>nom</sub>	3,7 W	5,7 W	7,8 W	9,8 W	11,8 W	13,9 W
	Q <sub>max</sub>	6,2 W	10,8 W	15,3 W	19,9 W	24,4 W	29,0 W
U-value [EN ISO 100077-2]		1,0 W/m <sup>2</sup> K					
Watertightness [in open position] [EN 13141-1:2004]		up to 150 Pa					
Height		110 mm					
Min. width		750 mm	1000 mm	1250 mm	1500 mm	1750 mm	2000 mm
Max. width		6000 mm					
Depth		320 mm [345 mm incl. rain cover]					
Filter		optional coarse 45% [G3] or ePM1 80% [F7] filter					
Device class		I					
Usable temperature-range		from -15 °C to +45 °C					
Resistant to frost		yes					
Condensation free		yes					
Voltage		230 V / 50 Hz					
Voltage of device [internal]		15 V DC					
Supply voltage		230 V <sub>AC</sub> ± 10%					



RENSON® Headquarters  
Maalbeekstraat 10, IZ 2 Vijverdam, B-8790 Waregem, Belgium  
Tel. +32 (0)56 62 71 11  
info@renson.eu  
www.renson.eu

